



Common Effluent Treatment Plants: Overview, Technologies and Case Examples

May, 2015

Common Effluent Treatment Plants: Overview, Technologies and Case Examples

Foreword



Dr. Dieter Mutz
Director
Indo German Environment Partnership (IGEP) Programme
Deutsche Gesellschaft für Internationale Zusammenarbeit (GIZ) GmbH
New Delhi

The on-going Indo German Development Cooperation has “urban and industrial environmental policy & management” as one of priority areas of cooperation. The Indo German Environment Partnership (IGEP) Programme forms a part of this priority area, under which technical cooperation is being provided to the identified Indian partner organizations by the Deutsche Gesellschaft für Internationale Zusammenarbeit (GIZ) GmbH, on behalf of the German Federal Ministry for Economic Cooperation and Development (BMZ).

The IGEP Programme, which is implemented jointly by the Ministry of Environment and Forests (MoEF) of the Government of India and GIZ has ‘Common Effluent Treatment Plants’ as one of the core topics. The overall objective of the technical cooperation on this core topic is, “To demonstrate innovative and financially sustainable solutions for Common Effluent Treatment Plants (CETPs)”.

Based on the work taken up on this core topic, the present document has been prepared. In the document, information has been put together on the problems faced by the sector, relevant environment friendly technologies and results of the case studies undertaken under the IGEP Programme.

We would like to place on record our sincere thanks to CII-Triveni Water Institute for facilitating articulation of the inputs in the report and also to Tamilnadu Water Investment Company Limited, Chennai, Enpro-Enviro Pvt. Ltd., Surat and University of Applied Sciences and Arts Northwestern Switzerland School of Life Sciences Institute of Ecopreneurship for helping us compiling various case studies from different wastewater management facilities.

We hope the document will be useful for the policy makers, regulators and the CETP operators alike for improving environmental performance of the CETPs.

22nd May, 2015

New Delhi

(Dr. Dieter Mutz)

Table of Contents

1	Overview of CETPs in India.....	11
1.1	Background.....	11
1.2	State-wise Distribution of CETPs	12
2	Standards, Legal Framework, Schemes.....	17
2.1	Standards/Permissible Limits	17
2.2	Legal Framework	19
	□ Delhi CETP Act	20
	□ RPCB Guidelines	21
2.3	Central Government Schemes/ Programmes	21
	□ Scheme of the Ministry of Environment & Forests, GoI.....	21
	□ IIUS- Industrial Infrastructure Up-gradation Scheme 2003 (under DIPP)	23
	□ Small Industries Cluster Development Programme.....	23
	□ Guidelines for Centrally Sponsored Scheme for Integrated Processing Development Scheme (IPDS)	24
	□ Scheme for Integrated Textiles Park (SITP).....	24
3	Technological Choice for the CETPs.....	24
3.1	Categories of Effluent Generating Industries	25
3.2	Quantitative Fluctuations of Effluent	25
3.3	Characteristics of the Effluent.....	25
3.4	Pre-treatment Requirements	27
3.5	Conveyance System	28
3.6	Disposal of Treated Effluents	28
3.7	Treatability and Choice of Technology	29
	□ Anaerobic treatment:.....	33
3.8	Zero Liquid Discharge (ZLD) Concept.....	46
	□ Driving Factors of ZLD in the CETPs – Example from Tamil Nadu:.....	47
	□ ZLD based system for tannery industries:.....	48
3.9	Recycle and Reuse of Technologies	52
3.10	Approach for Planning/Up-gradation of CETPs	55
4	Business Models for CETPs.....	61
4.1	Full Public Ownership.....	61
4.2	Full Private Ownership	61
4.3	Public Private Partnership	62
4.4	Special Purpose Vehicle (SPV)	64

4.5	Trustee Company as SPV	66
4.6	Role of Industrial Infrastructure Corporations	66
4.7	Financing Aspects.....	67
5	Management Models for CETPs	68
5.1	Independent O&M Agency	68
5.2	Multiple O&M Agencies	68
5.3	Overview of Business & Management Models in Tamil Nadu.....	68
6	Case Examples	71
6.1	Rayapuram Common Effluent Treatment Plant	71
6.2	Murugampalayam Common Effluent Treatment Plant	76
6.3	Arulapuram Common Effluent Treatment Plant	77
6.4	Chinnakarai Common Effluent Treatment Plant.....	80
6.5	PERTEC Common Effluent Treatment Plant	82
6.6	Gujarat Eco Textile Park Pvt. Ltd.....	85
6.7	Globe Enviro Care Ltd.....	86
6.8	New Palsana Industrial Co-Op. Society Ltd.....	87
6.9	Palsana Enviro Protection Ltd.	88
6.10	Pandesara Infrastructure Ltd.	89
6.11	Sachin Enviro Infrastructure Ltd.	89
6.12	SMS Waluj CETP Pvt. Ltd.....	91
6.13	CETP of Pattancheru Enviro-Tech Ltd. (Andhra Pradesh).....	92
6.14	CETP of Jawaharlal Nehru Pharma City at Visakhapatnam (Andhra Pradesh).....	92
6.15	Online Monitoring of Treatment Plants through CC Camerasat Tirupur	93
6.16	Combined CETP / STP Leverkusen-Bürrig, Chempark Leverkusen, Germany.....	94
6.17	CETP Basel Chemical Industry, ProRheno AG, Basel, Switzerland	97
6.18	Common Effluent Treatment Plant, Vapi: Approach for Retrofitting/ Modernisation	100
6.19	MANA Common Effluent Treatment Plant, Mallapur & Nacharam	106
6.20	Green Procurement Procedure: New CETP at APSEZ.....	107
7	Policy Interventions Required for CETPs.....	109
7.1	Summary of Key Concerns with CETPs	109
	<input type="checkbox"/> Design/technology related issues	109
	<input type="checkbox"/> Flow/conveyance related issues	110
	<input type="checkbox"/> Sludge disposal issues	110
	<input type="checkbox"/> Issues with Zero Liquid Discharge	110
	<input type="checkbox"/> Issues related manpower/capacities	111
	<input type="checkbox"/> Issues related to business models	111

□ Management related issues.....	111
7.2 Suggestive Policy Measures	111

Abbreviations

ACF	Activated Carbon Filter
ACR	Anaerobic Contact Reactor
AL	Aerated Lagoons
AOPs	Advanced Oxidation Processes
ASBR	Anaerobic Sequencing Batch Reactor
BAT	Best Available Techniques
BREFs	Best Available Techniques Reference documents
BOO	Build Own, Operate
BOOT	Build Own, Operate, Transfer
CETPs	Common Effluent Treatment Plants
CHEMCOT	Chennai Environmental Management Company of Tanners
CIEFs	Common Environmental facilities
CLC	Calcutta Leather Complex
CLCSS	Credit Linked Capital Subsidy Scheme
DAF	Dissolved Air Flootation
DINTEC	Dindigul Tanners Environ Control Systems
DMF	Dual Media Filter
EFS	Emissions From Storage
ENE	Energy Efficiency
EMFM	Electro Magnetic Flow Metering system
ETPs	Effluent Treatment Plants
EU	European Union
FFE	Falling Film Evaporator
FCE	Forced Circulation Evaporator
FSS	Fixed Suspended Solids
GAP	Ganga Action Plan
GIZ	Deutsche Gesellschaft für Internationale Zusammenarbeit
GMP	Good Manufacturing Practice
GTAB	Governing and Technology Approval Board
HEAF	High-Efficiency Air Filter
HSE	Health, Safety and Environment
HRT	hydraulic retention time
IDLS	Integrated Development of Leather Sector
IED	Industrial Emissions Directive
IGEP	Indo German Environment Partnership
MEE	Multiple Effect Evaporation system
MF	Micro Filtration
MFI	Micro Finance Institutions
MLD	Million Litres Per Day
MOC	Material Of Construction
MoEF	Ministry of Environment and Forests
MSME	Micro, Small and Medium Enterprise
MVR-E	Mechanical Vapour Recompression Evaporator
NF	Nano Filters
NGOs	Non-Governmental Organisations
NLDP	Leather Development Programme
NRCD	National River Conservation Directorate
PLIs	Primary Lending Institutions
PPP	Public-Private Partnership
O&G	Oil and grease
O&M	Operation and Maintenance

RANITEC	Ranipet Tannery Effluent Treatment Company Limited
RO	Reverse Osmosis
SBR	Sequential batch reactors
SCR	Selective Catalytic Reduction Of No _x
SEP	Solar Evaporation Pan
SEZ	Special Economic Zone
SFCs	State Financial Corporation's
SIDCs	State Industrial Development Corporations
SNCR	Selective Non-Catalytic Reduction Of No _x
SPCB	State Pollution Control Board
SPV	Special Purpose Vehicle
SRT	Solid Retention Time
SSI	Small Scale Industries
TCIDS	Textile Centres Infrastructure Development Scheme
TDS	Total Dissolved Solids
TNPCB	Tamil Nadu Pollution Control Board
TOC	Total Organic Carbon
TSDF	Treatment, Storage & Disposal Facility
TWIC	Tamil Nadu Water Investment Company Limited
UASB	Up Flow Anaerobic Sludge Blanket
UF	Ultra Filtration
WT	Waste Treatments in Industries
UNIDO	United Nations Industrial Development Organisation
VSS	Volatile Suspended Solids
WI	Waste Incineration
ZLD	Zero Liquid Discharge

1 Overview of CETPs in India

1.1 Background

The Indo German Development Cooperation has “Urban and Industrial Environmental Policy & Management” as one of the priority areas of cooperation. The Indo German Environment Partnership (IGEP) Programme forms a part of this priority area, under which technical cooperation is being provided to the identified Indian partner organisations by the Deutsche Gesellschaft für Internationale Zusammenarbeit (GIZ), on behalf of the German Ministry for Economic Cooperation and Development (BMZ).

The IGEP Programme, which is implemented jointly by the Ministry of Environment and Forests (MoEF) of the Government of India and GIZ has “Common Effluent Treatment Plants” as one of the core topics. The overall objective of the technical cooperation on this core topic is, “To demonstrate innovative and financially sustainable solutions for Common Effluent Treatment Plants (CETPs) for wastewater treatment”.

Under the Water (Prevention and Control of Pollution) Act, 1974, every industry is required to provide adequate treatment of the effluents generated by it before their disposal, irrespective of whether the disposal is in a stream, on land, into sewerage system or into sea. However, often the small-scale industries (SSIs), due to their limited size and scale of operations do not find it economically viable to install elaborate pollution control equipment. The Common Effluent Treatment Plants (CETPs) are considered a viable treatment solution for collective treatment of effluents, particularly from small and medium scale industries.

CETPs are seen as a solution to overcome the constraints associated with effluent treatment in the individual industries. CETPs could potentially help in achieving treatment of combined wastewater from various industries at lower unit costs and also help facilitate better compliance and monitoring with standards.

The country today has over 171 CETPs. There are several advantages as well as challenges associated with CETPs. The advantages of a CETP are:

- Facilitates small scale industries and helps reduce the wastewater treatment cost for individual units.
- Helps achieve ‘economy of scale’ in wastewater treatment.
- Helps optimize the cost of pollution abatement for each individual industry.
- Helpful for individual industries that lack manpower and technical expertise for the treatment of wastewater.
- Helpful for individual industries that lacks space for full-fledged treatment facilities.
- Helps in homogenization of wastewater and better hydraulic stability.
- Better control over treatment and disposal of wastewater.
- Eliminates multiple discharges of wastewater by individual industries and provides scope for recycling and reuse of treated wastewater, and proper handling of solid wastes generated from wastewater treatment.

However, there are several challenges associated with CETPs. As per a report of the Central Pollution Control Board (2005), less than 7% of CETPs in India is complying with wastewater discharge standards. To identify and address these challenges, under the IGEP Programme, information was collected on various CETPs, stakeholder consultations were organised and pilot studies taken up. Accordingly, the learnings have been brought out in the present Reference Document.

1.2 State-wise Distribution of CETPs¹

Presently, there are about 171 CETPs in India. The state-wise break-up of the CETPs are as given below-

Table no. 1.1- State-wise distribution of CETPs

S. No.	Parameter	Concentration (in mg/l)
1	Andhra Pradesh	6
2	Delhi	13
3	Gujarat	27
4	Haryana	11
5	J & K	1
6	Karnataka	9
7	Kerala	3
8	Maharashtra	27
9	Madhya Pradesh	1
10	Punjab	4
11	Rajasthan	13
12	Tamil Nadu	47
13	Uttar Pradesh	4
14	Uttranchal	4
15	West Bengal	1
	Total	171

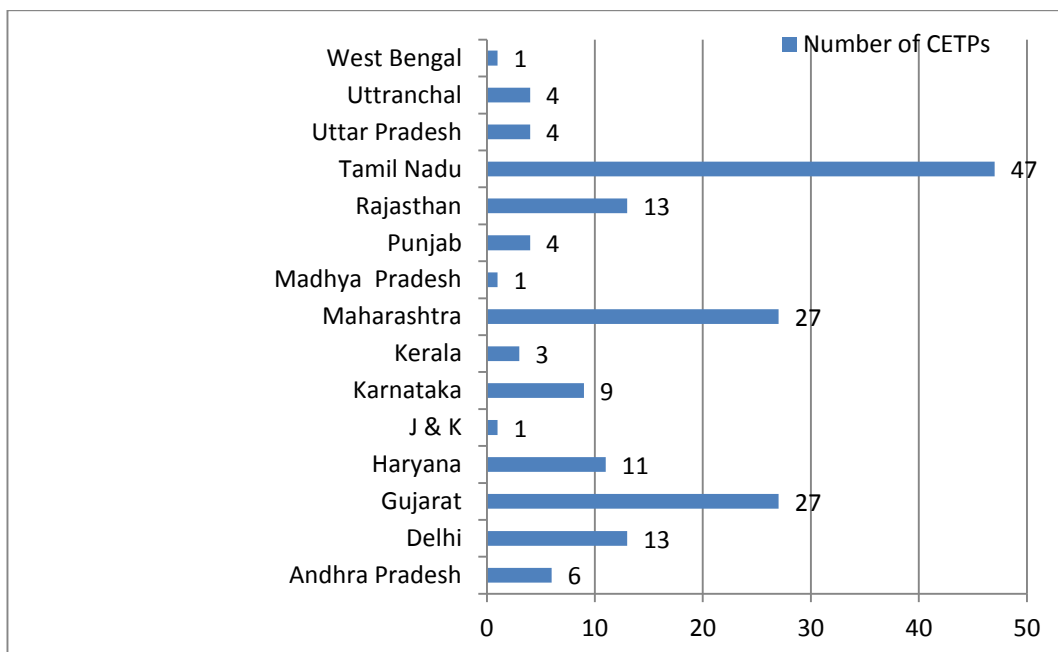

Fig. no. 1.1- Graphical representation of state-wise CETPs

Details of some of the CETPs are given in table below.

¹ MoEF presentation

Table no. 1.2- Partial list of CETPs, year of establishment, capacities and status

Name of the Zone	Name of CETP	Date of Commissioning	Volume of CETPs (MLD)	
Southern Zone				
Andhra Pradesh	Jeedimetla (JETL)	April,1989	15 (CPCB, NOV 2000)	
	Patancheru (PETL)	1989	7.50 (CPCB, NOV 2000)	
	Bollaram	1994	0.25(CPC B, NOV 2000)	
Karnataka	Kumbalgod Pai & Pai CETP (CPCB,Karnataka)	1994	0.3	
	Lidkar CETP, Bangalore	July, 1994	1	
	Bangalore Golf Club, Bangalore			
	CETP at ECO PARK, Peenya, Bangalore			
	CETP at Apparel Park at Doddaballapura			
	Eco Engineering Malur, Kolar			
	Kolhar Industrial Area, Bidar			
Tamil Nadu	Tiruppur	8 CETPs	1.5 to 10	
		Mannarai CETP, Tiruppur	1999	4.2
		Kashipalayam CETP, Tiruppur	1999	4
		Karaipudur CETP, Tiruppur	1999	10
		Manickapuram Pudur CETP, Tiruppur	1999	1.6
		Karungalpalayam CETP, Tiruppur	1999	4.25
		Andipalayam CETP, Tiruppur	1999	5
		Angeripalayam CETP, Tiruppur	1999	8.5
		Chinnakkarai CETP, Tiruppur	1999	5
	Karur	8 CETPs		
		Andan Koil CETP, Karur		1.25
		Karur Sukkaliyar,CETP, Karur		
		KKEL CETP, Karur	1999	1.3
		Sellandi Palayam CETP, Karur		
		Thiruvai CETP, Karur	1999	2.1

Name of the Zone	Name of CETP	Date of Commissioning	Volume of CETPs (MLD)
	Valandi Dyeing CETP, Karur		
	Karur Taluk Dye & Bleaching CETP, Karur		1.35
	Amaravathi Poll Tech CETP, Karur	1999	2.4
	Vellore	10 CETPs	
	TALCO Vaniyambadi, Valayampet, CEPT, Vellore	May,1991	2.8
	TALCO Vaniyambadi, Udayendiram CEPT, Vellore	January,1996	0.2
	TALCO Perinambut CETP	August,1995	0.9
	TALCO Ambur Thuthipet CETP, Vellore	November,1994	2
	Visharam CETP, Melvisharam Vellore	October,1996	3.4
	TALCO Ranipet CETP, Vellore	February,1996	4
	Melpudupet CETP, Ambur, Vellore		
	Ambur Mallgalthope CETP, Vellore	August,1998	1.1
	SIDCO Ranipet CETP, Vellore	December,1995	2.5
	SIDCO Phase II CETP Ranipet, Vellore		
	TALCO Dindigul CETP	December,1996	2.5
	TALCO Madhavaram CETP, Chennai	January, 1997	0.4
	Ranitec		4
Villarasampatti CETP			
Pallavaram	February,1995	3	
Northern Zone			
Delhi	Anand Parbat		24 (CETP Society (Regd.), 2008)
	Badli	2003	12
	G.T.Karnal Road	2002	6
	Jhilmil	2004	16.8
	Lawrence Road	2004	12
	Mangolpuri	2001	2.4
	Mayapuri	2003	12
	Mohan co-op		1.8
Nariana		21.6	

Name of the Zone	Name of CETP	Date of Commissioning	Volume of CETPs (MLD)
	Najafgarh Road		9.6
	Nangloi	2003	12
	Okhla Indl. Area	2003	24
	Okhla Indl. Est.		1.2
	S.M.A.	2003	12
	Wazirpur	2003	24
Uttar Pradesh	Banthal		4.5
	Jajmau, Kanpur	1994	36
	Unnao	1996	2.15
	Mathura	1997	6.25
Haryana	Kundli CETP, Sonipat	1999	1.1
Punjab	Phillore	1996	0.035
	Jalandhar	1997 - was closed for last 2yrs	1.5
Western Zone			
Gujarat	Vapi	January, 1997	70
	Vatva, Ahmedabad	April, 1998	16
	Nandesari Vadodara	November, 1994	5.5
	Naroda CETP, Ahmedabad	July, 1999	3
	Ankleshwar	February, 2005	1.8
	BEAIL, Ankleshwar		60
	Sachin (0.5 MLD)		0.5
	Sachin(50 MLD)	Under commissioning	50
	Sarigam, Valsad	1994	0.4
	Dhadeshwar CETP, Jetpur	1995	0.15/.055
	Jetpur, Rajkot	1989	20
	Kalipat, Rajkot		0.035
	Kotadasangani, Rajkot		0.01
	Washing Ghat, Jetpur, Rajkot		20
	Odhav, Ahmedabad	January, 1998	1.2
	Gumsav, Odhav, Ahmedabad	1998	1.5
	GVMMS Industrial Estate, Odhav, Ahmedabad		1
	Panoli		1
	Sanand CETP, Paldi, Ahmedabad	1997	0.2
	Sanand CETP, Vendor Park		2
	Narol CETP, Ahmedabad	2001	0.1
	Balva Eco. Project		1
	Tirupathi agro Industries		1.5
	Kadodara, Surat		100
	GIDC, Surat		100
	Junagadh		5
	Bhesan, Junagadh		30
	Kalol, Gandhinagar		0.4
	Changodar, Ahmedabad		0.75
	Baleshwar, Surat		60
	Palsana, Surat		45

Name of the Zone	Name of CETP	Date of Commissioning	Volume of CETPs (MLD)
	Jamnagar		0.04
	Gyaspur		100
	Padra CETP		2.25
Maharashtra	Dombivelli CETP Phase-I	2003	14
	Dombivelli CETP Phase-II	March, 1999	1.5
	Thane-Belapur CETP	November, 1997	12
	Tarapur CETP	June, 1994	2
	Taloja CETP	November, 1999	10
	ACMA CETP, Ambernath	March, 1997	0.25
	Chikhlole Morivali CETP Ambernath		0.8
	Ambernath CETP(Additional)	Under commissioning	7.5
	CETP LK Akiwate Jaysinghpur	December, 1997	1
	PRIA CETP Patalganga	Feb, 2001	15
	CETP MMA Mahad CETP	2002-2003	7.5
	Badlapur CETP		8
	CETP RIA, ROHA		
	CETP Lote Parshuram		
	CETP Solapur		
	CETP Kurkumbh MIDC		
	CETP Ranjangaon		
	CETP Sangli-Miraj		
	Waluj Effluent Treatment Project LTD		
	Ichalkaranji Textile Development Cluster Ltd. Parvati Indl. Estate		
Ichalkaranji Textile Development Cluster Ltd. Ichalkaranji			
Ichalkaranji Textile Development Cluster Ltd. Laxmi Coop Ind. Estate Yadrav			
Kagal CETP, Kagal			
Butibari CETP, Nagpur		5	
West Bengal	Calcutta Leather Complex (CLC)	March, 2004	6 modular units of 5 MLD each
Central Zone			
Rajasthan	Balotra CETP Unit I	2000	6
	Jasol	2005	2.5
	Bithuja		30
	Jodhpur	July, 2004; under stablization	20
	Bhiwadi	Trial-2004	6(2.5 ind.+3.5 sewage)

Name of the Zone	Name of CETP	Date of Commissioning	Volume of CETPs (MLD)
	Pali CETP Unit I	1983	5.2
	Pali CETP Unit II	1997	8.4
	Pali CETP Unit III	1999	9
	Machheri CETP Jaipur	2002	0.6
Madhya Pradesh	Govindpura CETP	2000	0.9

2 Standards, Legal Framework, Schemes

2.1 Standards/Permissible Limits

The Environmental Protection Rules, 1986 provide standards for Common Effluent Treatment Plants. These standards apply to discharges from industries to an inlet of a CETP as well as to the CETP itself for treating and discharging the effluents. The inlet effluent standards for CETPs are shown in table no. 2.1.

Table no. 2.1- Inlet effluent standard² for CETPs

S. No.	Parameter	Concentration (in mg/l)
1	pH	5.5-9.0
2	Temperature, °C	45
3	Oil & Grease	20
4	Phenolic compounds (as C ₆ H ₅ OH)	5.0
5	Ammonical Nitrogen (as N)	50
6	Cyanide (as CN)	2.0
7	Hexavalent Chromium	2.0
8	Total Chromium	2.0
9	Copper	3.0
10	Lead	1.0
11	Nickel	3.0
12	Zinc	15.0
13	Arsenic	0.2
14	Mercury	0.01
15	Cadmium	1.0
16	Selenium	0.05
17	Fluoride	15.0
18	Boron	2.0
19	Radioactive Material	-
20	Alpha emitters, Hc/ml	10 ⁻⁷
21	Beta emitters Hc/ml	10 ⁻⁸

² **Source:** Guidelines for management, operation and maintenance of common effluent treatment plants, CPCB publications, programme objective series: problems/81/2001-2002

The treated effluents standards as specified for the CETP are represented in the following Table no. 2.2.

Table no. 2.2- Treated effluent standards³

S. No.	Parameter	Concentration (in mg/l)		
		Into Inland Surface Water	On Land for Irrigation	Into Marine Coastal Areas
1.	PH	5.5 – 9.0	5.5 - 9.0	5.5-9.0
2.	BOD ₅ 20°C	30	100	100
3.	Oil & Grease	10	10	20
4.	Temperature °C	40°C	-	45°C at the point of discharge
5.	Suspended solids	100	200	a) Process water- 100 b) Cooling water- 10% above total suspended matter of influent
6.	Dissolved solids (inorganic)	2100	2100	-
7.	Total residual Cl	1.0	-	1.0
8.	Ammonia (as N)	50	-	50
9.	Total Kjeldahl Nitrogen (as N)	100	-	100
10.	Chemical oxygen demand (COD)	250	-	250
11.	Arsenic (As)	0.2	0.2	0.2
12.	Mercury (Hg)	0.01	-	0.01
13.	Lead (Pb)	0.1	-	1.0
14.	Cadmium (Cd)	1.0	-	2.0
15.	Chromium (Cr)	2.0	-	2.0
16.	Copper (Cu)	3.0	-	3.0
17.	Zinc (Zn)	5.0	-	15
18.	Selenium (Se)	0.05	-	0.05
19.	Nickel (Ni)	3.0	-	5.0
20.	Boron (B)	2.0	2.0	-
21.	percent Sodium	-	60	-
22.	Cyanide (CN)	0.2	0.2	0.2
23.	Chloride (Cl)	1000	600	-
24.	Fluoride (F)	2.0	-	15
25.	Sulphate (SO ₄)	1000	1000	-
26.	Sulphide (S)	2.8	-	5.0
27.	Pesticides	Absent	Absent	Absent
28.	Phenolic compounds (as C ₆ H ₅ OH)	1.0	-	5.0

³ Source: (<http://www.lawsindia.com/Industrial%20Law/k57.htm>)

2.2 Legal Framework

The important environmental laws related to CETPs are:

- the Water (Prevention and Control of Pollution) Act, 1974
- the Air (Prevention and Control of Pollution) Act, 1981
- the Environment (Protection) Act, 1986 and the Environmental (Protection) Rules, 1986; and
- the Hazardous Waste (Management, Handling & Transboundary Movement) Rules, 2008

Brief details are given below.

“Consent” is required to be taken from the regulatory authorities for establishment as well as operation of CETPs under the Water (Prevention and Control of Pollution) Act, 1974 for discharge of effluents and under the Air (Prevention and Control of Pollution) Act, 1981 for emission of air pollutants from the process of treatment are applicable to CETPs. The State Pollution Control Board in the State or the Pollution Control Committee in the Union Territory, as the case may be, is the regulatory authority to grant “consent”. While granting consent, the quantity of effluent/emission and concentration of pollutants, the mode of collection, their treatment, the mode of disposal of effluent and compliance with standards are taken into consideration.

In addition to the air and water acts, the Environment (Protection) Act, 1986 also applies to CETPs. In Schedule–1 of the Environmental (Protection) Rules, 1986, the standards for emission or discharge of environmental pollutants are prescribed, including primary treatment standards that are to be complied at the inlet to CETP.

Also, as per the Environmental Impact Assessment (EIA) notification of Ministry of Environmental & Forests, Gol dated 14.9.2006 of the Environmental (Protection) Act, 1986, setting up of any new CETP and the modernisation or expansion of any existing CETP, requires to undergo through the Environmental Impact Assessment process and seek prior Environmental Clearance. All CETPs fall under Category ‘B’, however ‘General Conditions’ apply, as per which under certain conditions the CETPs could fall under Category ‘A’.

The EIA process involves the public in an open and participatory manner and allows for the effective integration of environmental considerations and public concerns into decision making. The EIA study has to comprise following:

- Project description and need
- Pertinent institutional information
- Identification of potential impacts
- Description of effected environment
- Impact prediction
- Impact assessment
- Impact mitigation
- Selecting the proposed action
- Preparing the written documentation
- Environmental monitoring and management plan

The Environment (Protection) Act, 1986 is also applicable for proper management of hazardous waste generated during treatment of effluent, as per the Hazardous Waste (Management, Handling & Transboundary Movement) Rules, 2008 under this Act. Under these rules, “authorization” is required for generation, handling, collection, reception,

treatment, storage, recycling, reprocessing, recovery, reuse and disposal of hazardous wastes.

In addition, Delhi and Rajasthan are the two states, which have attempted to address the framework requirement for running the CETPs. In the case of Delhi, it is known as an Act since it is passed by the legislative assembly and in the case of Rajasthan a set of guidelines has been issued. Details are given below.

► **Delhi CETP Act⁴**

Delhi has enacted a special law on CETPs. The Delhi Common Effluent Treatment Plants Act, 2000 was passed by the legislative assembly of the National Capital Territory of Delhi. It provides the framework and mechanism for recovery of the dues as arrears of land revenue in respect of the capital and recurring costs of common effluent treatment plants setup in the industrial estates in the National Capital Territory of Delhi and matters connected therewith or incidental thereto. The Act defines constitution, powers and functions of appropriate authority to run CETP in the National Capital Territory of Delhi.

Following are the key features of this Act:

- Have provisions for the recovery of the dues as arrears of land revenue in respect of the capital and recurring costs. Any amount due under this Act (including any interest or penalty payable under clause 10 or clause 11, as the case may be) from any person may be recovered by the Government in the same manner as an arrear of land revenue. Provided that the appropriate authority may for the reasons to be recorded in writing, allow payment of amount due in instalments.
- Any area included in the jurisdiction of any CETP Society shall be registered under the Societies Registration Act, 1860 (21 of 1860)
- The CETPs shall be operated and maintained effectively and efficiently by the CETP societies subject to such conditions as may be specified by a notification issued by the Government.
- In case the Government considers that the CETP society has failed to effectively and efficiently discharge its duties of operation and maintenance then after giving due notice as prescribed by rules, the Government may by notification in the Official Gazette authorize any non-government organization, local body or any such other authority as it may consider fit to operate and maintain the plant efficiently and effectively.
- Constitution of appropriate authority responsible for up gradation and technology.
- Penalty would be imposed on the person for failing not paying the due amount.

The Delhi Common Effluent Treatment Plant Rules, 2001 has the following important provisions for the CETP Societies:

- To collect contributions from industries located in the estate towards the cost of construction, maintenance, operation and up-gradation of CETP.
- To manage, maintain and operate the CETP in accordance with the prescribed

⁴ Source: (http://delhi.gov.in/DoIT/DoIT_Industry/PDF/acts&rules/CETP_ACT_rules.pdf)

standard of the Environment (Protection) Act, 1986 (29 of 1986), the Water (Prevention and Control of Pollution) Act, 1974 (6 of 1974), and the Air (Prevention and Control of Pollution) Act, 1981 (14 of 1981).

- To upgrade technology of the installed CETP as per future requirements.
- To arrange CETP funds by way of contributions, grants or loan with or without security or on the security of a mortgage charge or on hypothecation or pledge of overall or any of the immovable or movable properties/stores/consumables belonging to the CETP Society.
- To allow entry and inspection of the CETP and related installations/offices/ documents, stocks, consumables, stores, etc. to the officers of the authorities/local bodies.
- Apportionment of recurring cost: The recurring cost of the CETP shall be completely by the occupiers in the estate.

► **RPCB Guidelines⁵**

In connection with abatement of pollution in the textile industry, the Rajasthan Pollution Control Board (RPCB) has issued a set of guidelines, which has direct implications on the CETPs catering to these textile industries.

The pertinent points are:

- In industrial clusters like Pali, Jodhpur, Balotra etc., the industrial units are treating the raw effluents through Common Effluent Treatment Plants (CETP), which are established, operated and maintained by a Trust elected by the member units.
- Separate guidelines have been provided for the member units and the Trusts for clear demarcation of role and responsibilities.
- The standards for inlet of CETP and treated effluent quality of CETP are to be followed.
- For each CETP and its constituent units, the State Board will prescribe standards as per the local needs and conditions, and will be applied to the small scale industries, i.e., industries with total discharge up to 25 KLD.

2.3 Central Government Schemes/ Programmes

▪ **Scheme of the Ministry of Environment & Forests, Govt⁶**

The Ministry of Environment & Forests (MoEF) has been implementing a centrally sponsored scheme for CETPs since 1991. In the light of the operational deficiencies in the earlier scheme of 1991 and taking into consideration the development of pollution control technologies over the years, the financial constraints on the part of SSI proponents and the recommendations of the State Pollution Control Boards, MoEF came up with revised guidelines for central assistance to CETPs. As per the revised guidelines, the financial assistance for a CETP project shall be as follows:

1. The central assistance (subsidy) will be restricted to 50% of the total project cost. The

⁵ Source: http://www.indiaenvironmentportal.org.in/files/file/Guidelines_textile_industry_draft.pdf

⁶ Source: (<http://moef.nic.in/downloads/public-information/rev-guid-2011.pdf>)

modified ratio proposed in respect of central share: state share: proponent share will be 50:25:25. Out of the proponents share, at least 40% of contribution has to be from the proponent and balance 60% is to be raised through loan to the proponent from Banks/ Financial Institutions.

For CETPs involving primary / secondary/ tertiary treatment, financial assistance would be provided by the Government of India to the tune of 50% of maximum Rs. 1.50 crore / MLD capacity, subject to a ceiling of Central assistance of Rs. 15 crore per CETP. For CETPs involving primary/secondary/ tertiary treatment and ZLD (zero liquid discharge) treatment, financial assistance would be provided by MoEF to the tune of 50% of maximum Rs. 4.50 crore / MLD capacity, subject to a ceiling of Central assistance of Rs. 20 crore per CETP.

2. Central subsidy shall be released subject to two conditions:
 - a) The state subsidy is made available to the CETP project;
 - b) Bank guarantee for an equivalent amount has been procured by the SPCB/ PCC
 3. No assistance will be provided for meeting recurring or operation and maintenance costs.
 4. The central assistance will be provided only to meet capital costs towards following items:
 - a) Plant and machinery for primary, secondary, and tertiary treatment.
 - b) On site laboratory with standard set of instruments.
 - c) Zero Liquid Discharge (ZLD) and related technologies.
 5. From MoEF, the central assistance will be available for:
 - a) Establishment of new CETPs in an industrial estate or a cluster of SSLs.
 - b) Up gradation/ modernization proposal for CETPs earlier financed through the MoEF shall be considered for one time funding. However, there has to be adequate justification for the same and the time interval between the commissioning of the existing CETP and the submission of proposal for up gradation/ modernization to the Central Government should not be less than 5 years.
 6. MoEF shall prepare a panel of technical institutions for technical evaluation of a CETP proposal/ DPR.
- **Modified Guidelines of Micro and Small Enterprises - Cluster Development Programme (MSE-CDP)⁷**

As part of the Cluster Development Programme, the modified guidelines have been published for micro and small enterprises, summary of which are given below-

- » Point 9 refers to hard interventions which includes creation of tangible "assets" as common facility centres (CFCs) like effluent treatment plant, marketing display/selling centre, common logistics Centre, common raw material bank/sales depot, etc.

⁷ Source: (<http://pharmaceuticals.gov.in/ClusterPharma.pdf>)

- » The Gol grant will be restricted to 70% of the cost of project of maximum Rs 15 crore. Gol grant will be 90% for CFCs in North East and hill States.
- » Clusters with more than 50%, (a) micro/ village, (b) women owned, and (c) SC/ST units. The cost of project includes cost of land (subject to max. of 25% of project cost), building, pre-operative expenses, preliminary expenses, machinery & equipment, miscellaneous fixed assets, support infrastructure such as water supply, electricity and margin money for working capital.
- » The common facility should be maintained by the SPV with certain conditions.

▪ **IIUS- Industrial Infrastructure Up-gradation Scheme 2003 (under DIPP)**

The IIUS - Industrial Infrastructure Up-gradation Scheme, launched in December 2003, is a Central Government Scheme. The objective of the Scheme is to enhance competitiveness of the industry by providing quality infrastructure to existing industrial clusters through Public-Private Partnership mode (PPP). CETPs are also eligible under this Scheme. The funding pattern is presented in the table below (Table no. 2.3).

Table no. 2.3- Funding Pattern under IIUS

Source	Percentage Of Project	Remark
Central grant	Up to 75% of the project cost with a ceiling of 50 crore. The ceiling has been raised to Rs. 60 crore under recast IIUS	Up to 90% of the project in case of North Eastern States, Jammu & Kashmir, Himachal Pradesh and Uttarakhand
Industry contribution/ user contribution	Minimum 15% of the project cost is mandatory. The SPV has to arrange the additional fund.	Minimum 5% of the project cost in case of North Eastern States, Jammu & Kashmir, Himachal Pradesh and Uttarakhand
State government	May contribute if it likes	
<i>Central grant for creation of capital assets only, not for working capital</i>		

▪ **Small Industries Cluster Development Programme⁸**

The Small Industries Cluster Development Programme of the Ministry of Micro, Small and Medium Enterprises of Gol provides fund support to CETP under the category of support provided for, (i) Developmental (DV) and (ii) Commercial (CL).

Contribution of the Ministry to the total cost of the project is decided keeping in view the willingness of other stakeholders and partners like state governments, industry associations, firms in the cluster etc. Implementing agencies (including state governments, cluster beneficiaries and/or their SPVs) are expected to mobilise resources to fund the remaining costs, as detailed in the guidelines issued on the Scheme.

⁸[http://www.ilfclusters.com/sites/default/files/PDF/SupportingScheme/3-GuidelinesoftheSmallIndustriesClusterDevelopmentProgramme\(SICDP\).pdf](http://www.ilfclusters.com/sites/default/files/PDF/SupportingScheme/3-GuidelinesoftheSmallIndustriesClusterDevelopmentProgramme(SICDP).pdf)

- **Guidelines for Centrally Sponsored Scheme for Integrated Processing Development Scheme (IPDS)⁹**

The Textile Ministry, Govt. of India had in the 11th Five Year Plan launched a scheme for Integrated Textile Parks (ITP). Based on the experience of the above scheme as well as the peculiar challenges faced by the textile processing sector the Ministry has decided to formulate a new programme called as “Scheme for Integrated Textile Processing Development” (IPDS).

IPDS proposes to establish 4-6 brown field and 3-5 green field projects addressing the needs of the existing textile clusters. Eligible projects under the scheme would cover the following:

- » Group A - Water treatment & effluent treatment plant and technology (including marine, riverine and ZLD).
- » Group B – Common infrastructure such as captive power generation plants on technology preferably renewable/green technology,
- » Group C – Common facilities such as testing laboratories and R&D centers.

- **Scheme for Integrated Textiles Park (SITP)¹⁰**

The ‘Scheme for Integrated Textile Parks (SITP)’ was approved in the 10th Five Year Plan to provide the textile industry with world-class infrastructure facilities for setting up their textile units by merging the erstwhile ‘Apparel Parks for Exports Scheme’ (APES) and ‘Textile Centre Infrastructure Development Scheme (TCIDS)’.

The scheme targets industrial clusters/locations with high growth potential, which require strategic interventions by way of providing world-class infrastructure support. The project cost covers common infrastructure and buildings for production/support activities, depending on the needs of the ITP.

This Scheme is implemented through special purpose vehicles (SPVs), where industry associations/group of entrepreneurs are the main promoters of the integrated textiles park (ITP). At each ITP, there would be a separate special purpose vehicle (SPV) formed with the representatives of local Industry, financial institutions, state and central government.

3 Technological Choice for the CETPs

No one solution fits all and as such selection of right technologies is very crucial to ensure sustainability of the CETPs. Many CETPs in India are finding it difficult to treat the effluent to the standards prescribed. Quite often, this may be attributed to the inadequate planning at the stage of designing and commissioning of the new plants. This chapter attempts to document the existing technological models in use for CETPs.

“Technological model” refers to the combination of various treatment systems adopted by a CETP. The treatment systems pertain to physico-chemical treatment (primary), biological treatment (secondary), advanced treatment depending on the characteristics of effluents and other peripheral systems like conveyance system and sludge disposal etc.

Various factors that influence technological model of the CETPs include the following:

⁹ http://texmin.nic.in/policy/GUIDELINES_FOR_IPDS.pdf

¹⁰ <http://texmin.nic.in/policy/apparel%20manufacturing%20units%20guidelines.pdf>

- Types/categories of effluent generating industries
- Quantitative fluctuations of effluent
- Characteristics of the effluent
- Pre-treatment requirements
- Conveyance system
- Disposal
- Treatability and choice of technology (treatment methods/systems, available techniques/technologies etc.)

Details are given below.

3.1 Categories of Effluent Generating Industries

The industries that discharge their effluent to a CETP can be homogeneous or heterogeneous type.

In the case of homogenous industries, all the industries fall in the same industry sector and involve similar quality of wastewater. But, in the case of heterogeneous industries, the discharges are from different sectors and involve wide variations in quantity and quality of effluent.

For homogeneous industries, the quantitative and qualitative fluctuations may be in the predictable range due to similar process operations, however, the heterogeneous industries demand a greater flexibility with respect to the treatment units that are able to handle wide range of fluctuations.

3.2 Quantitative Fluctuations of Effluent

The quantitative and qualitative fluctuations of effluent determine the volume of equalization tank. The variations of the hydraulic load and qualitative fluctuations have to be equalised to avoid shock loads onto the CETP.

The effluent quantity and flows need to be carefully assessed. The assessment can be made from the following:

- » Data furnished by the industries, including water balance.
- » Estimation based on the products manufactured by an industry.
- » Data from consent applications available with the pollution control boards.
- » Measurement of flow in the drains/sewers (in the case of existing industries).

While arriving at the size of the CETP with respect to quantity of effluent, various unit operations considered should be sized and layout prepared with provisions to add additional treatment units in future depending on the projected growth rate of the specific (type/nature) industries in the region.

Flow rate is another important aspect in determining the size of CETP. Minimum and maximum flows and temporal variations (hourly, daily, seasonally etc.) have to be assessed. Anticipated future increase in flow should also be taken into consideration. Temporal flow variations require use of equalization ponds to allow a constant flow rate through downstream processes.

3.3 Characteristics of the Effluent

Analysis of effluent characteristics to determine the units in a treatment process scheme is a critical step. The technological choice is very much influenced by the characteristics of the effluent. Treatability of mixed effluent streams that are generated from various types of

industries is a complex issue for arriving at a treatment scheme and ensuring its successful operation.

Biodegradability reflects how easily or rapidly the wastewater is treatable by microorganisms and is one important parameter that largely defines the technological model. The effluents could be broadly categorised into the following types based on biodegradability:

- » Easily bio-degradable (COD/BOD < 2)
- » Not-easily biodegradable (COD/BOD > 2)
- » Not easily bio-degradable and toxic (high TDS, high COD, toxicants)

▪ **Physical characteristics of effluents:**

- » Temperature – Observation of temperature of effluents is useful in indicating the solubility of oxygen, which affects oxygen transfer capacity of aeration equipment's and rate of biological activity.
- » Colour and odour – Indicates the colloidal portion and need for specific treatments chemical/membrane units.
- » Total and volatile suspended solids - Total solids include both the suspended solids and the dissolved solids, which are obtained by separating the solid and liquid phase by evaporation.
- » Suspended solids are a combination of settleable solids and non-settleable solids, which are usually determined by filtering a wastewater sample through a glass fiber filter contained in a Gooch crucible or through a membrane filter. Settleable solids are those, which usually settle in sedimentation tanks during a normal detention period. This fraction is determined by measuring the volume of sludge in the bottom of an Imhoff cone after one hour of settling.

For testing, solids remaining after evaporation or filtration are dried, weighed, and then ignited. The loss of weight by ignition at $500^{\circ}\text{C}\pm 50^{\circ}\text{C}$ is a measure of the volatile solids, which are classed as organic material. The remaining solids are the fixed solids, which are considered as inorganic (mineral) matter. The suspended solids associated with volatile fraction are termed volatile suspended solids (VSS), and the suspended solids associated with the mineral fraction are termed fixed suspended solids (FSS).

▪ **Chemical characteristics of effluents:**

- » pH: The biological treatment units at CETP are sensitive to pH of the effluent. Thus, this parameter is of high importance. Besides, acidic effluents cause corrosion related problems to the CETP.
- » Carbonaceous substrates: Carbonaceous constituents are measured by BOD, COD or TOC analysis. While BOD has been the common parameter to characterize carbonaceous material in wastewater, COD is becoming more common in most current comprehensive computer simulation design models.
- » BOD test: The BOD test gives a measure of oxygen utilized by bacteria during the oxidation of organic material contained in a wastewater sample. The test is based on the premise that all the biodegradable organic material contained in the wastewater sample will be oxidized to CO_2 and H_2O , using molecular oxygen as the electron acceptor. Hence, it is a direct measure of oxygen requirements and an indirect measure of biodegradable organic matter.

- » COD test: The COD test is based on the principle that strong oxidizing agents under acidic conditions oxidize most organic compounds to CO₂ and H₂O. COD will always be equal or higher than BOD, as the test is under strong oxidizing agent, which oxidizes to greater extent, including inorganics.
- » Total organic carbon (TOC): The total carbon analyzer allows a total soluble carbon analysis to be made directly on an aqueous sample. In many cases, TOC can be correlated with COD and occasionally with BOD values. As the time required for carbon analysis is generally short, such co-relations are extremely helpful for efficient control of day-to-day operations of treatment plant.
- » Toxic metals and compounds: Some heavy metals and compounds such as chromium, copper, etc., will determine the precipitation of biological treatment. Various considerations will determine the choice of treatment.

▪ **Segregation of wastewater:**

Segregation of wastewater with special characteristics, for example based on high inorganic (TDS) streams or high COD streams etc., plays an important role in dealing with treatment in CETPs. The wastewater quality aspects with respect to chemical contamination can be grouped as follows.

- Nutrients: Phosphorous; Nitrogen
- Trace organics: Industrial chemicals; Endocrine disruptors; Disinfection byproducts; Pharmaceuticals; Pesticides.
- Heavy metals: Lead, Zinc, Cadmium, Mercury etc.
- Salts: Sodium, Chloride, Bromide etc.

Effluent streams could be broadly segregated for combining appropriately, based on their suitability for a specific treatment choice. A typical model approach for segregation of streams is given below.

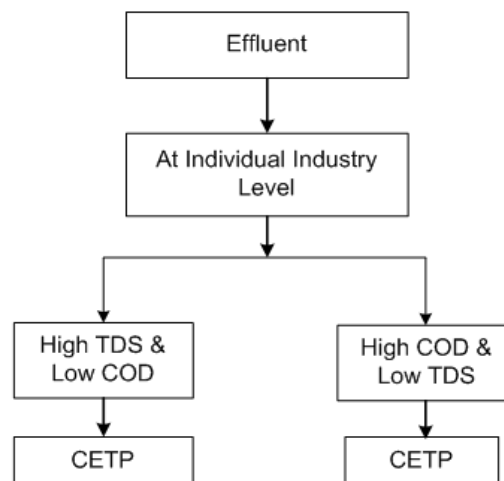

Fig. no. 3.1- Categories of effluent streams

3.4 Pre-treatment Requirements

To avoid CETPs becoming sinks of raw effluents from the industries, which poses problems for treatment of wastewater in a CETP, the inlet effluent standards have been specified so that only suspended solids and biodegradable matter will be treated at CETP facilities.

Standards are shown in table no. 2.1 for inlet effluent quality as well as treated effluent quality for CETPs. It is essential that the industries that discharge their wastewater into CETP are strictly adhering to the inlet standards of the CETP.

3.5 Conveyance System

The usual means of effluent conveyance systems are:

- Tankers
- Pipelines/sewers (gravity / pressurized)
- Open channels
- Hybrid system (tankers and pipelines)

Pipelines/sewers in various industrial estates/areas face problems of corrosion, besides problem of choking, resulting in damage to pipelines/sewers. Another problem faced by CETPs is uncontrolled discharge in terms of quantity and quality (not meeting inlet standards/limits) and/or illegal discharge by units, especially those that are not permitted to discharge due to “zero liquid discharge” condition or other similar conditions in the “consent to operate” issued to industries by the pollution control boards.

To overcome such problems, many CETPs have adopted conveyance of effluents through tankers. The rubber-lined tankers do not have corrosion problem, and the inlet characteristics and flows from industries can be properly checked before accepting the effluent. However, for large quantity of effluents, conveyance through tankers is not feasible.

Due to requirement of different treatment systems for treatment of effluents, more than one pipeline/sewer system may be required for conveyance of effluents. The tanker system may be additionally needed for small quantity of segregated effluent, (such as electroplating/pickling wastewater, high TDS wastewater for treatment in Multi Effect Evaporator etc.). The material of construction has to be appropriately selected depending on the effluent characteristics. CETPs for tanneries effluent have adopted two-pipeline system, one for high salt containing effluent known as soak liquor and another for rest of the effluent, in order to treat separately. The soak liquor goes for solar evaporation and other effluents are treated by physico-chemical followed by biological treatment.

3.6 Disposal of Treated Effluents

The modes of disposal for treated effluents are:

- On land for irrigation
- Surface water bodies – canals, drains, lakes, rivers etc.
- Public sewers
- Sea, marine outfall
- Recycle/reuse
- Solar evaporation
- Through tankers
- Disposal to a final CETP or STP

While the CETP outlet standards have to be complied with, these standards would be made stricter depending on the place of disposal of the treated wastewater and its sensitivity. Accordingly, the type of technologies to be employed in the treatment would vary.

3.7 Treatability and Choice of Technology

▪ Treatment Methods/Systems ¹¹

Different forms of treatment exist depending on the quantity and quality of wastewater. The effluent from industrial processes requires some form of pre-treatment prior to sending the effluents for further treatment of CETP. This is mainly required when wastewater is carried through pipe lines to minimize corrosion and clogging and to prevent toxic constituents. For ensuring proper pre-treatment, standards are specified under the Environment (Protection) Act, 1986 for the effluent quality at the inlet to CETPs. In addition, reduction of wastewater quality and quantity at source is also an important component. The treatment system, in general, includes:

- » Conventional system (Physico – Chemical and biological treatment)
- » Conventional with tertiary system (pressure filtration, activated carbon, additional physico – chemical treatment)
- » Additional system (MEE, Advance oxidation process, Ammonical-nitrogen removal)

In the European Union (EU), the Best Available Techniques (BAT) describe the environmental standard that industrial installations have to apply in order to get the required operation permit. It means the most advanced stage of production techniques and their methods of operation, which can be implemented in a particular industrial sector under economically, and technically viable conditions and which provide the most effective protection of the environment as a whole.

The wastewater treatment process can be divided into four to five major steps. Fig 3.2 shows the typical unit operations of a CETP.

1. **Segregation at source:** Segregation of waste streams at source enables to treat differentiated stream as per its specific characteristics which in turn would raise treatment effectiveness.
2. **Preliminary treatment:** It involves a number of unit processes to eliminate undesirable characteristics of wastewater. Processes include use of screen, grit chambers for removal of sand and large particles, comminators for grinding of coarse solids, pre-aeration for odour control and removal of oil and grease.
3. **Primary treatment:** It involves removal of settleable solids prior to biological treatment. The general treatment units include: flash mixer + flocculator + sedimentation.
4. **Secondary treatment:** It involves purification of wastewater primarily with dissolved organic matter by microbial action. A number of processes are available but the ones that are mainly used are anaerobic and /or aerobic treatment methods.
5. **Tertiary treatment:** This mainly includes physical and chemical treatment processes that can be used after the biological treatment to meet the treatment objective

¹¹ EIA Technical Guidance Manual for CETPs prepared for MoEF by IL&FS Ecosmart Ltd., Sept. 2009

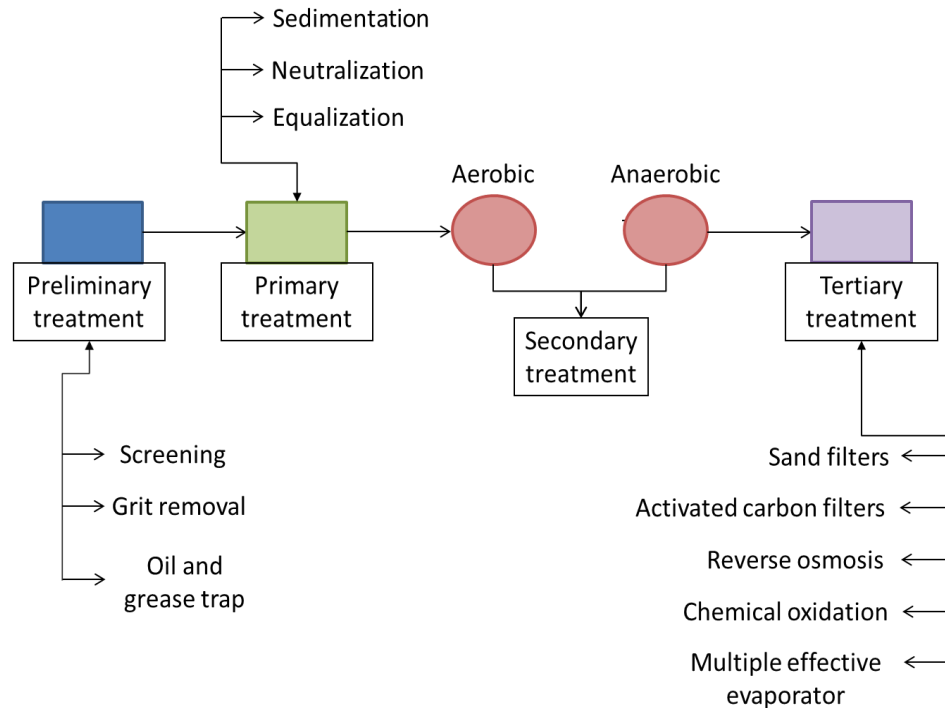

Fig. no. 3. 2- Showing typical unit operations in CETPs

▪ Primary treatment

Various options are available for pre-treatment. Primary treatment includes equalization for wastewaters having varying quantities and quality of flow. Neutralization is applicable for highly acidic and alkaline effluents. Sedimentation is used for separation of suspended particles. Suspended solids are removed through gravitational settling or settling tanks or clarifiers or settling using coagulants etc. Dual Media Filters (DMF), which have two layers of media, i.e. sand and anthracite, are also used to remove suspended solids, and are also effective in removal of colour, odour and also reduces the organic matter associated with the suspended matter.

Preliminary treatment involves a number of unit processes to eliminate undesirable characteristics of wastewater. Processes include use of screen, grit chambers for removal of sand and large particles, comminutors for grinding of coarse solids, pre-aeration for odour control and removal of oil and grease.

- Screening: It is adopted to remove floating matter and shall be provided at the intake point
- Grit removal: Grit removal is used when WWTP has to deal with rainwater which normally entrains a considerable amount of sand
- Oil and grease removal: Oil and grease are skimmed-off by passing the wastewater through skimming tank. This process can be more efficient by Dissolved Air Floatation or Vacuum Floatation.

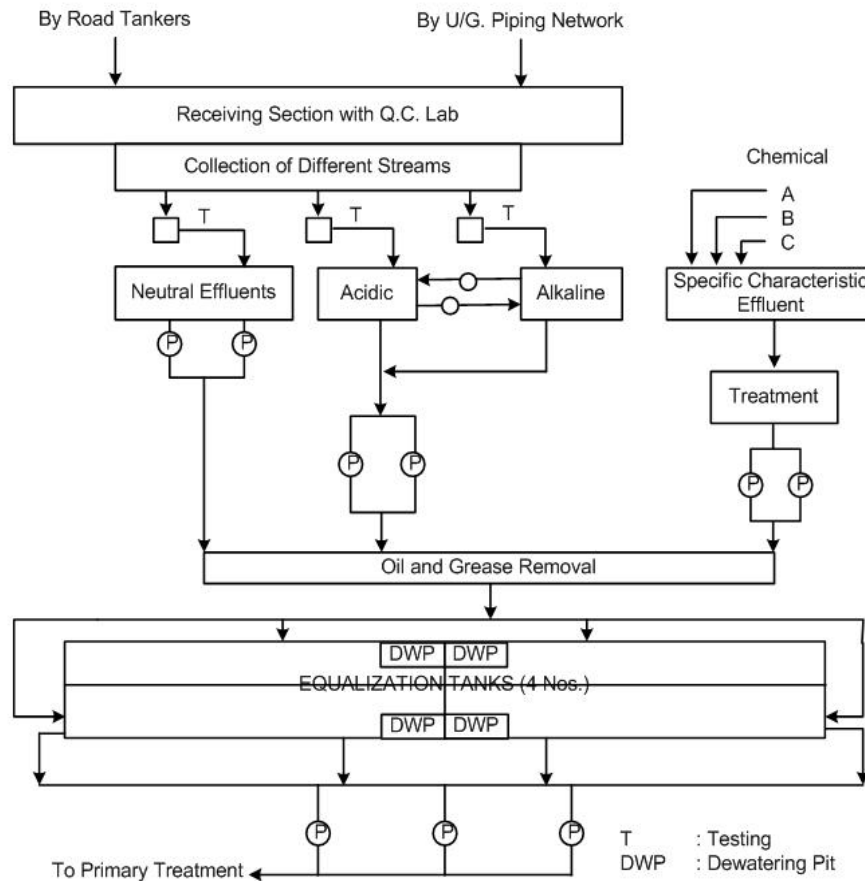

Fig. no. 3.3- Typical collection and preliminary treatment at CETP

Primary treatment also involves removal of settable solids prior to biological treatment. The general treatment units include: flash mixture+ flocculation+ sedimentation.

- ▶ **Equalization:** Applicable for wastewaters having different characteristics at different intervals of time and where uniform treatment is required. Each unit volume of waste is mixed thoroughly with other volumes of other wastes to produce homogeneous and equalized effluent.
- ▶ **Neutralization:** Applicable for highly acidic and alkaline effluents. This can be done by treatment with lime or lime slurry or caustic soda.
- ▶ **Sedimentation:**
 - Separation of suspended particles by gravitational settling and floatation material.
 - Separates heavy metals or other dissolved components after preceding flocculation process.
 - Removes suspended solids in the primary clarifier.
 - Removes biological sludge in secondary clarifier of a biological wastewater treatment plant (CETP).

Dual Media Filter (DMF) unit: Dual media filter unit is used to improve suspended solids level in primary settling unit. Dual Media Filter (DMF) has two layers of media, viz. sand and anthracite that are effective in removal of colour and odour along with TSS. Incidentally, it also reduces the organic matter associated with the suspended matter so removed. It may also

remove a small fraction of organic matter associated with colloidal matter that is coagulated and filtered during filtration. If DMF unit or a rapid sand filter unit is over loaded, it will require frequent backwashing.

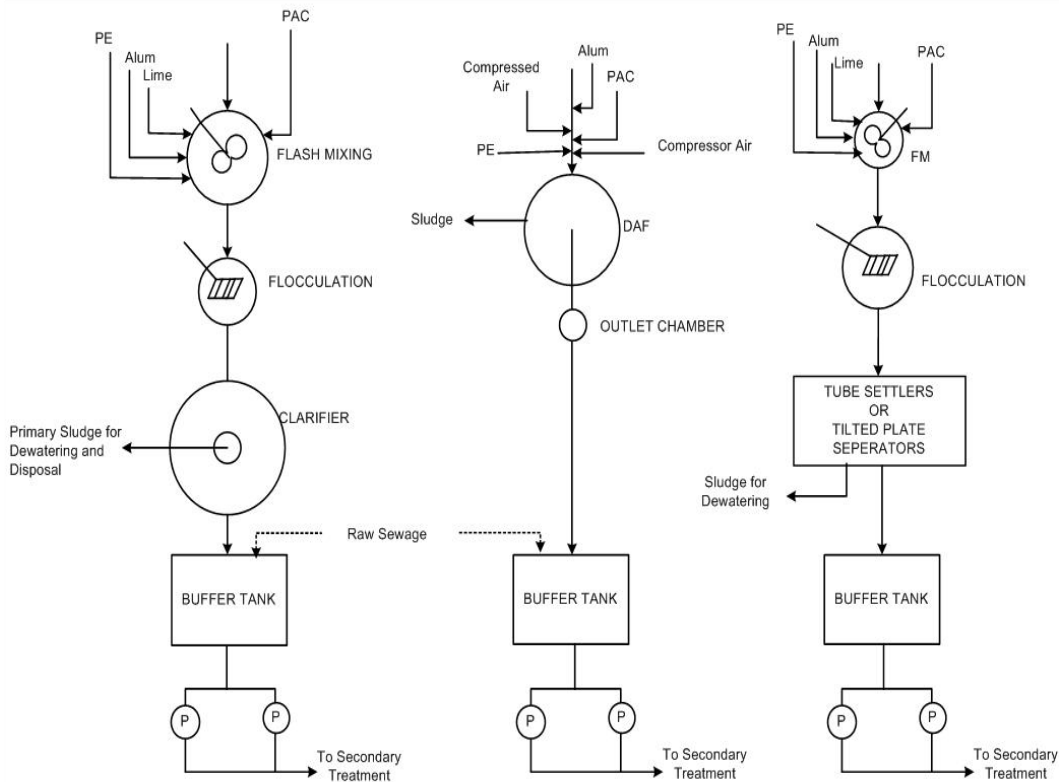

Fig. no. 3.4- Typical primary treatment scheme

▪ **Secondary treatment**

Secondary treatment involves purification of wastewater primarily with dissolved organic matter by microbial action. A number of processes are available but the ones that are mainly used anaerobic and/or aerobic treatment methods.

► **Aerobic treatment**

- **Dissolved Air Flotation (DAF) units:** Dissolved Air Flotation (DAF) has gained widespread usage over the last forty years for the removal of suspended solids (TSS), oils and greases (O&G), and biological oxygen demand (BOD) from wastewater and other industrial process streams. DAF systems are frequently used to provide wastewater pre-treatment, product recovery and thickening of biological solids in industries ranging from food processing to pulp and paper to petrochemicals.
- **Activated Sludge Process:** The effluent from primary treatment processes are collected in aeration tank and are aerated with mechanical devices such as fixed/ floating/ diffused aeration/ oxygen injection etc. Oxygen is supplied to the aeration zone to initiate the sludge decomposition and provide agitation to promote the flocculation of fine particle, which then settle out. Here the removal of BOD and COD is found to be the maximum. Oxidation and removal of soluble or suspended solids is the result of the activated sludge process in waste treatment. Sludge production, oxygen requirements, and nutrients requirements are dependent on SRT (Solid

Retention Time).

- **Aerated Lagoons:** The effluent from primary treatment processes are collected in lagoons and are aerated with mechanical devices such as floating/ fixed aerators.
- **Trickling Filters/ Bio Filters:** In the trickling or percolating filter processes, the micro-organisms are attached to a highly permeable medium through which the waste is trickled- or percolated. These are used when the effluent is highly loaded with COD.
- **Sequential Batch Reactors (SBR):** There are five stages of treatment process, viz. fill, react, settle, decant and idle, which take place in batches. These are used to reduce BOD COD.
- **Submerged Aerobic Fixed Film Reactor:** This technology utilizes an aerobic fixed film process that is a combination of submerged attached growth and activated sludge process. This system has two compartments, while the first provides majority of BOD removal, the second polishes BOD.
- **Membrane Bioreactor:** It is particularly suitable for effluents with high COD and/or Ammoniacal Nitrogen loads, where recycling of wastewater is envisaged, stringent discharge regulations are to be complied with and the receiving water body is sensitive.

► **Anaerobic treatment:**

- **Anaerobic Contact Reactor (ACR):** The wastewater is mixed with recycled sludge and digested in a sealed reactor. The wastewater-sludge mixture is externally separated (sedimentation, or vacuum fine screening flotation) and the supernatant wastewater is sent for further treatment.
- **Upflow Anaerobic Sludge Blanket (UASB):** In this, the wastewater is introduced at the bottom of the reactor, from where it flows upward through a sludge blanket composed of biologically formed granules or particles. This technology is effective in removing BOD and COD.
- **Fixed Bed Reactor:** In this anaerobic filter process, the wastewater flows upwards or downwards (depending on the solids content of the influent) through a column with various types of solid media on which anaerobic micro-organisms grow and are retained.

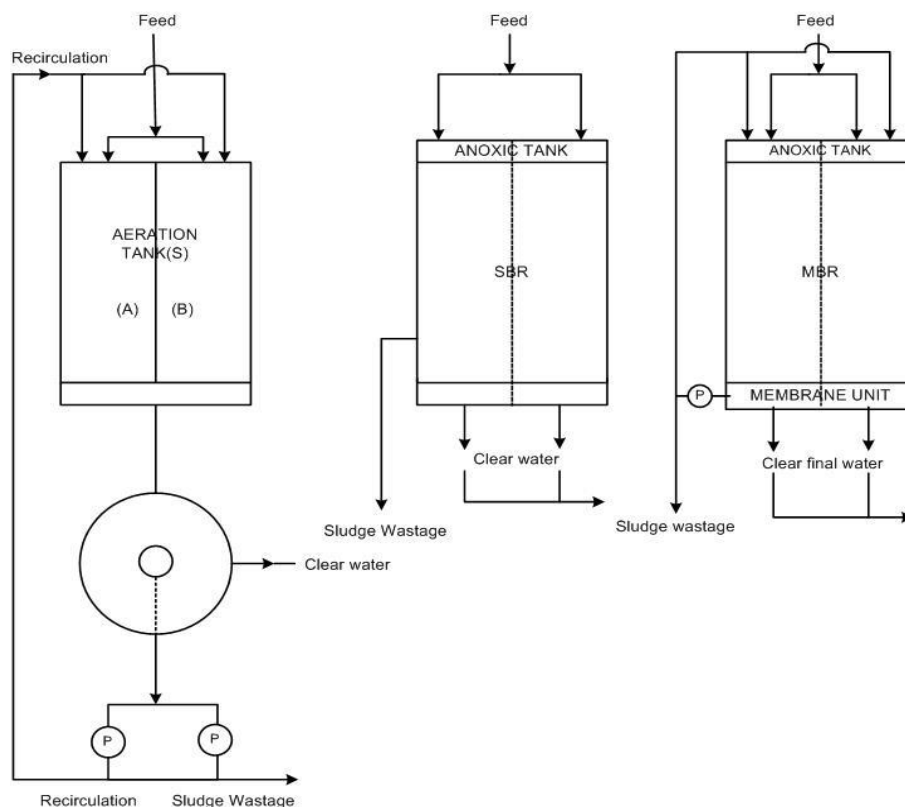

Fig. no. 3.5- Typical biological treatment flowchart

The following table summarizes the treatment common treatment technology adopted for soluble non-biodegradable particles as per Best Available Techniques Reference Document from the European Commission.

Table no. 3.1- Non-biodegradable Particles / Physico-chemical Treatment

Process Name	Description	Environment Benefit
Chemical Precipitation	To form particulates that can be separated from water by other process like sedimentation, etc.	Heavy Metals (Zn, Ni, Te, Al), organic/ inorganic, oils, greases, etc.
Crystallization	Precipitate is formed on seed material like sand, etc.	Heavy Metals (Zn, Ni, Te, Al)
Chemical Oxidation	Conversion of pollutants to less harmful / easily biodegradable organic components like H ₂ O ₂	COD, TOC, AOX, oil, Phenol, CN, SO ₃ , PAH
Reduction	Conversion of pollutants to less harmful / easily biodegradable organic components like SO ₄ , etc.	Cr(VI), Cl, Hypochlorite, H ₂ O ₂
Hydrolysis	Destruction of chemicals into smaller compounds	COD, AOX
Nano-filtration/ Reverse Osmosis	Permeation of liquid through membrane, to be segregated into permeates and concentrate. Driving force is pressure difference	Hg, Pesticides, TOC, SO ₄ , PO ₄ , Salts, HM

Process Name	Description	Environment Benefit
Electro-dialysis	Ions are transported through ion permeable membranes under the influence of potential gradient	Ions & concentrate for reuse/ recycle
Adsorption	Transfer of soluble substances from wastewater phase to the surface of the solid	Hg, COD, Pesticides, Phenols, NH ₄ , AOX
Ion Exchange	Removal of hazardous ions & replacement with more desirable ions	Ions, HM, SO ₄ , NO ₃
Extraction	Transferring soluble contaminants into solvent	Phenols, COD,
Pertraction	Removes by absorption into organic extraction agent	Phenols, COD, AOX
Distillation	Separation by transferring into vapor phase	Phenols, organics
Membrane Distillation	Thermally driven process where vapor is transported through hydrophobic membranes	Non-volatile (ions, acids, colloids), VOCs
Electrolysis	Electric current is applied to WW yielding chemical changes in composition of Wastewater	Metal ions (can be reused / recycle)
Evaporation	Water is volatile substance and concentrate remains at the bottom	Contaminants
Pervaporation	Combination of permeation and vaporisation	VOCs,
Stripping	Contact with high flow of a gas current to transfer volatile pollutant from water to gas phase	Ammonia, NH ₄ -N, N, VOCs, Phenols, Sulphide, COD

▪ Tertiary treatment

- » **Sand filters:** Removes undissolved pollutants such as suspended solids, undissolved phosphate, and attached organics. (e.g., CETPs in Karur, Tamil Nadu have installed sand filters.)
- » **Media Filtration:** Suspended solids, Turbidity, Color, and Odor and Iron for water are removed depending on the impurities present in water. (e.g. CETP Vatwa, Gujarat has installed multimedia filtration unit).
- » **Activated Carbon Filter (ACF):** It is employed for removal of trace organics, such as pesticides, phenols, etc., and heavy metals, which escape the primary treatment. If the final effluent being subjected to has high BOD and COD, then ACF will result in an early exhaustion of its activated carbon bed. Therefore, in such cases ACF is a misfit because very frequent replacement or regeneration of the bed is neither easy nor economically affordable.
- » **Microfiltration:** In Microfiltration, TSS and large colloidal particles are rejected while macromolecules and TDS pass through the Micro Filtration membranes.
 - Applied when solid free wastewater for downstream facilities is desired such as reverse osmosis or complete removal of hazardous contaminations.

- Used in metal particle recovery and treatment of metal plating wastewater.
 - Used for sludge separation after activated sludge process in a central biological wastewater treatment plant, thereby replacing secondary clarifier.
- » **Ultra Filtration:**
- Ultra filtration (UF) is midway between Micro Filtration (MF) and Nano Filtration.
 - It is a pre-treatment step prior to RO or ion exchange.
 - Removes pollutants such as proteins and other macromolecular compounds and toxic non-degradable components.
 - Separates heavy metals after precipitation.
 - Separates compounds not readily degradable in sewage treatment effluents, which are subsequently recycled to the biological stage.
 - Removes SS along with attached COD as a polishing step.
- » **Retention Ponds:**
- Used to avoid hydraulic overload of downstream facilities.
 - Separates solid pollutants (such as sediment, organic matter, dissolved metal compounds and nutrient) from rainwater.
- » **Nano Filtration:**
- Nano filtration, in concept and operation, is much the same as reverse osmosis. The key difference is the degree of removal of monovalent ions such as chlorides.
 - Applied to remove larger organic molecules and multivalent ions in order to recycle and reuse the wastewater or reduce its volume
 - Increase the concentration of contaminants to such an extent that subsequent destruction processes are feasible.
 - This process is used most often for total dissolved solids removal, with the purpose of softening (polyvalent cation removal) and removal of disinfection by-product precursors such as natural organic matter, pharmaceutical applications and synthetic organic matter.
- » **Reverse Osmosis (RO):**
- Separates water and dissolved constituents down to ionic species.
 - It is observed that salinity, primarily due to salts of sodium, is the primary contributor to the high TDS problem as high TDS is almost invariably accompanied by high Chlorides and Sodium concentration. TDS reduction is possible by softening process if TDS is mainly due to salts of divalent cations, but if it is mainly due to salts of mono-valent cations then Reverse Osmosis (RO) is a technical option.
 - It is often used in combination with post treatment techniques for the permeate.
- » **Ion Exchange:**
- Ion Exchange is the removal of undesired or hazardous ionic constituents of wastewater and their replacement by more acceptable ions from an ion exchange resin, where they are temporarily retained and afterwards released into a regeneration or backwashing liquid.

» **Evaporation:**

It is applicable to remove or concentrate inorganic.

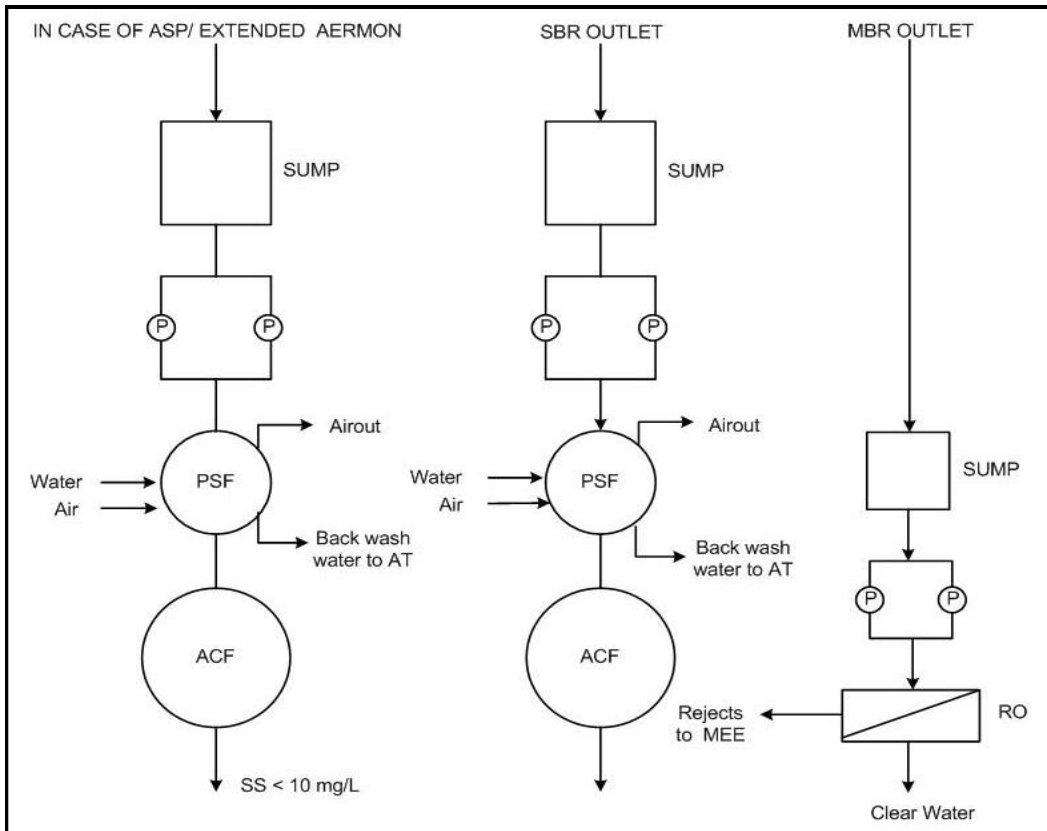

Fig. no. 3.6- Typical tertiary treatment

▪ **Typical treatment options**

Based on characteristics of the wastewater, appropriate technologies can be identified to arrive at the probable combination of treatment technologies in a treatment scheme. One such guidance matrix is given below.

Table no. 3.2- Wastewater Characteristic - Specific Treatment Options

Characteristics	Quality of Effluent	Treatment Options
High TDS, and high COD and equivalently high BOD	Waste is not easily biodegradable but toxic	<ul style="list-style-type: none"> ▪ Thermal decomposition (based on calorific value) ▪ Chemical oxidation by hydrogen peroxide, ozone etc. ▪ Evaporation + secured landfill
High TDS, High COD and high difference between COD and BOD	May be toxic; not suitable for biological treatment; mostly inorganic salts	<ul style="list-style-type: none"> ▪ Chemical treatment (recovery, precipitation etc.) ▪ Evaporation + secured landfill of evaporated residue
High TDS, high BOD and low difference between COD & BOD	Highly organic effluent fully biodegradable	<ul style="list-style-type: none"> ▪ Anaerobic + Aerobic treatment ▪ If quantity is less, incineration (based on calorific value) + secure landfill of incineration ash
High TDS, low BOD and low BOD & COD difference	Only inorganic salts, no need for biological treatment	<ul style="list-style-type: none"> ▪ Solar evaporation ▪ Forced evaporation (after separation of volatile organic matter) ▪ Membrane technologies
Low TDS, and high COD and equivalently high BOD	Highly organic effluent, may not be easily biodegradable	<ul style="list-style-type: none"> ▪ Thermal decomposition ▪ Chemical oxidation by hydrogen peroxide or ozone or sodium hypochlorite etc. ▪ Chemical + biological treatment
Low TDS, High COD and high difference between COD and BOD	Highly inorganic effluent, not suitable for biological treatment	<ul style="list-style-type: none"> ▪ Chemical recovery ▪ Chemical oxidation + biological treatment
Low TDS, high BOD and low difference between COD & BOD	Organic effluent, fully biodegradable	<ul style="list-style-type: none"> ▪ Anaerobic + aerobic treatment
Low TDS, low BOD and low BOD & COD difference	Low organic and low inorganic effluent	<ul style="list-style-type: none"> ▪ Recycle and reuse (after preliminary treatment)

NEERI has developed a template which may be used as a broad guideline for selection of technology depending upon the kind of wastewater that needs to be treated. The template is presented in the Fig-3.3.

Final ranking of pre-treatment technologies as per NEERI study are:

- » OZ – ASP – PSF – ACF
- » CP – ASP – CP – PSF – ACF
- » CP – ASP – PSF – DMF – MF

[OZ – Ozonation, ASP – Activated Sludge Process, ACF – Activated Carbon Filters, CP – Chemical Precipitation, PSF – Pressure Sand Filter, DMF – Dual Media Filter, MF – Media Filter]

WWC	High BOD	Low BOD	High COD
High TDS	(Highly organic effluent fully biodegradable) •Anaerobic + aerobic / •Incineration + secure landfill	(Organic salt, no need for biological treatment) •Solar, forced evaporation •Membrane technologies	(Waste not easily biodegradable but toxic) •Thermal destruction •Chemical treatment •Chemical oxidation •Evaporation + Secured landfill
Low TDS	Organic effluent, fully biodegradable :- •Anaerobic + aerobic treatment	(Low organic & inorganic effluent) •Recycle and reuse after preliminary treatment	(Highly organic effluent not easily biodegradable) •Thermal destruction •Chemical oxidation •Chemical + biological treatment
	-	-	Highly inorganic effluent, not suitable for biological treatment :- •Chemical recovery •Chemical oxidation+ biological treatment

Source: Common Effluent Treatment Plants-State of the Art, NEERI 1991, Sponsored by Ministry of Environment & Forests, Technical EIA Guidance for Common Effluent Treatment Plants, ILFS Eco Smart Ltd, Hyderabad 2010, Prepared for Ministry of Environment & Forests.

Fig. no. 3.7- Selection of technology based on wastewater quality ⁵

Following table presents a summary of the various treatment options and efficiency of removal that may be expected from these options.¹²

Table no. 3.3- Summary of Various Pre-treatment Options

Performance	Treatment option	Efficiency (%)
High	Chemical precipitation→bio-oxidation→chemical precipitation→sand filtration →activated carbon adsorption	BOD : 84-93 COD : 80-90 SS : 77-98
	Chemical precipitation→bio-oxidation→sand filtration→dual media filtration	
	Chemical precipitation (3 stage)→media filtration→activated carbon adsorption	
	Ozonation→bio-oxidation→sand filtration→activated carbon adsorption.	
Moderate	Electro-coagulation→bio-oxidation→chemical precipitation→sand filtration→activated carbon adsorption.	BOD : 68-79 COD : 60-73 SS : 64-78
Low	Bio-oxidation→sand filtration→dual media filtration→activated carbon adsorption	BOD : 56-70 COD : 48-65 SS : 52-74
	Chemical precipitation→sand filtration→activated carbon adsorption	
	Catalytic oxidation	BOD : 24-25 COD : 21-23 SS : 56-60

▪ **Best Practices in Wastewater Treatment as per EU BREF Document**

The ‘Best Available Techniques; (BAT) describes the environmental standard that industrial installations in the European Union (EU) have to apply in order to get the required operation permit. It means the most advanced stage of production techniques and their methods of operation, which can be implemented in a particular industrial sector under economically and

¹² Presentation from Mr. M. Karthik, Sr. Scientist, NEERI, at the CETP Workshop Organised by CII and GIZ at GBC Hyderabad, November 23, 2012

technically viable conditions, and which provide the most effective protection of the environment as a whole.

The EU Directive on Integrated Pollution Prevention and Control (IPPC) from 1996 – as well as its successor, the Industrial Emissions Directive (IED) from 2010 – strive for the prevention or reduction of emissions to air, water and soil, as well as waste reduction. To this end, it regulates which kinds of industrial installations need a permit for operation, and it stipulates that permit conditions such as emission limit values and other constructional or operational requirements have to be based on the application of BAT.

In order to define what is considered as BAT for a particular industrial sector, the EU implemented an information exchange between its Member States, representatives from industry and non-governmental organisations (NGOs). This process is coordinated through the European Integrated Pollution Prevention and Control (IPPC) Bureau. The major outcome of this process are the so-called Best Available Techniques Reference documents (BREFs), which were elaborated for all relevant industrial and agricultural sectors in the EU (more than 30 sectors!). These documents provide a lot of useful information for the particular sector, e.g. on the general techniques and processes in use, on the main environmental issues, on the current emission and consumption levels, on BAT candidates and finally on the best available techniques for the sector. After formal publication of the BAT conclusions in the European Gazette, they have to be implemented by the competent authorities and put into practice within 4 years.

As a reference for an environmentally sound construction and operation of industrial installations, the BREFs are also widely applied outside the EU. The BREFs are a valuable – but free of charge¹³ – source of information for Common Waste Water and Waste Gas Treatment/ Management Systems in the Chemical Sector, amongst others.

The meaning of BAT is summarised below:

- **Best** = most effective with respect to the prevention and – where that is not practicable – the reduction of emissions and the impact on the environment as a whole.
- **Available** = developed on a scale which allows implementation in the relevant industrial sector, under economically and technically viable conditions, taking into consideration the costs and advantages, whether or not it is used in the respective Member State.
- **Technique** = includes both the technology used and the way in which the installation is designed, built, maintained, operated and decommissioned.

As elaborated in the BREF document, the main sources of **waste water** in the chemical industry are:

- » chemical syntheses
- » waste gas treatment systems
- » conditioning of utility water
- » bleed from boiler feed water systems
- » blowdown from cooling cycles
- » backwashing of filters and ion exchangers
- » landfill leachates
- » rainwater from contaminated areas, etc.,

¹³ Reference Document on Best Available Techniques in Common Waste Water and Waste Gas Treatment/ Management Systems in the Chemical Sector can be downloaded from <http://eippcb.jrc.es/reference/>

Their main impact is characterised by:

- » hydraulic load
- » content of pollutant substances (expressed as load or concentration)
- » effect or hazardous potential on the receiving water body, expressed as surrogate or sum parameters
- » effect on organisms in the receiving water body, expressed as toxicity data.

Waste gas emissions appear as:

- » ducted emissions, which are the only emissions that can be treated
- » diffuse emissions
- » fugitive emissions.

The main air pollutants are:

- » VOCs
- » sulphur compounds (SO₂, SO₃, H₂S, CS₂, COS)
- » nitrogen compounds (NO_x, N₂O, NH₃, HCN)
- » halogen compounds (Cl₂, Br₂, HF, HCl, HBr)
- » incomplete combustion compounds (CO, C_xH_y)
- » particulate matter.

On treatment technologies, the BREF document covers:

a) Separation or clarification techniques (to protect from clogging, damage, fouling):

- Grit separation
- Sedimentation
- Air flotation
- Filtration
- Microfiltration/ultrafiltration

b) Physico-chemical treatment techniques (for inorganic or non-biodegradable waste water):

- Crystallisation
- Chemical oxidation
- Supercritical water oxidation
- Chemical reduction
- Hydrolysis
- Nano filtration/reverse osmosis
- Adsorption
- Ion exchange
- Extraction
- Distillation/rectification
- Evaporation
- Stripping
- Incineration

c) Biological treatment techniques (for bio-degradable waste water)

- Anaerobic digestion process
 - Anaerobic contact process
 - UASB

- Fixed bed
 - Expanded bed
 - Biological removal of sulphur compounds & heavy metals
 - Aerobic digestion process
 - Activated sludge process
 - Membrane bio-reactor process
 - Trickling filter
 - Expanded bed process
 - Bio-filter-bed
- d) **Nitrification/de-nitrification**
- e) **Central biological waste water treatment**
- f) **Waste gas treatment techniques**
- **for VOC and inorganic compounds:**
 - membrane separation
 - condensation
 - adsorption
 - wet scrubbing
 - bio-filtration
 - bio-scrubbing
 - bio-trickling
 - thermal oxidation
 - catalytic oxidation
 - flaring
 - **for particulate matter:**
 - separator
 - cyclone
 - electrostatic precipitator
 - wet dust scrubber
 - fabric filter
 - catalytic filtration
 - two-stage dust filter
 - absolute filter (HEPA filter)
 - high-efficiency air filter (HEAF)
 - mist filter
 - **for gaseous pollutants in combustion exhaust gases:**
 - dry sorbent injection
 - semi-dry sorbent injection
 - wet sorbent injection
 - selective non-catalytic reduction of NO_x (SNCR)
 - selective catalytic reduction of NO_x (SCR).

There are separate BREF documents to deal with the following:

Reference document	Subject
Emissions from Storage (EFS)	Emissions from tanks, pipe work and stored chemicals
Energy Efficiency (ENE)	General energy efficiency

	Generation of steam and electricity in pulp and paper
General Principles of Monitoring (MON)	Emissions and consumption monitoring
Waste Incineration (WI)	Waste Incineration
Waste Treatments in Industries (WT)	Waste Treatment

Some of the BAT options with reference to wastewater treatment as reflected in the EU BREF document are described below.

► **Wastewater collection system**

An adequate wastewater collection system plays an essential role in effective wastewater reduction and/or treatment. It ducts the wastewater streams to their appropriate treatment device and prevents mixing of contaminated and uncontaminated wastewater.

- » Segregate process water from uncontaminated rainwater and other uncontaminated water releases. If existing sites do not yet operate water segregation, it can be installed, atleast partially, when major alterations are made to the site.
- » Segregate process water according to its contamination load.
- » Install a roof over areas of potential contamination wherever feasible.
- » Install separate drainage for areas of contamination risk, including a sump to catch leakage or spillage losses.
- » Use over ground sewers for process water inside the industrial site between the points of wastewater generation and the final treatment device(s). If climatic conditions do not allow over ground sewers (temperatures significantly below 0 °C), systems in accessible underground ducts are a suitable replacement. Many chemical industry sites are still provided with underground sewers and the immediate construction of new sewer systems is normally not viable, but work can be done in stages when major alterations to production plants or the sewer system are planned
- » Install retention capacity for failure events and fire-fighting water in the light of a risk assessment.

► **Breaking and/or remove emulsions at source**

For suspended solids (TSS) (TSS that include heavy metal compounds or activated sludge need other measures), remove them from wastewater streams when they could cause damage or failure to downstream facilities or before they are discharged into a receiving water. Common techniques are:

- » Sedimentation / air flotation to catch the main TSS load
- » Mechanical filtration for further solids reduction
- » Microfiltration or ultrafiltration when solid-free wastewater is required.

► **Recovery of substances**

- » Control odour and noise by covering or closing the equipment and ducting the exhaust air to further waste gas treatment, if necessary.

- » Dispose of the sludge, either by handing it to a licensed contractor or by treating it on site.

As heavy metals are chemical elements that cannot be destroyed, recovery and re-use are the only ways to prevent them being released into the environment. Any other option causes them to be transferred between the different media: wastewater, waste air and landfilling. Thus, for heavy metals, the following techniques could be used:

- » Segregate wastewater containing heavy metal compounds as far as possible.
- » Treat the segregated wastewater streams at source before mixing with other streams.
- » Use techniques that enable recovery as widely as possible.
- » Facilitate further elimination of heavy metals in a final WWTP as a polishing step, with subsequent treatment of sludge, if necessary.

The appropriate techniques are:

- » Precipitation / sedimentation (or air flotation instead) / filtration (or microfiltration or ultrafiltration instead)
- » Crystallisation
- » Ion exchange
- » Nanofiltration (or reverse osmosis instead)

The inorganic salt (and/or acid) content of wastewater can influence both the biosphere of a receiving water, e.g. small rivers when they are confronted with high salt loads, and the operation of sewerage systems, e.g. corrosion of pipes, valves and pumps or malfunction of downstream biological treatment. In the case of one or both of these possibilities, the best available technique is to control the inorganic salt content, preferably at source and preferably with control techniques that enable recovery. Appropriate treatment techniques (not including techniques for treating heavy metals or ammonium salts) are:

- » Evaporation
- » Ion exchange
- » Reverse osmosis
- » Biological sulphate removal (used only for sulphate, but when heavy metals are present, they are also removed).

► **Pollutants unsuitable for biological treatment** are, e.g. recalcitrant TOC and/or toxic substances that inhibit the biological process. Thus their discharge into a biological treatment plant needs to be prevented. It is not possible to forecast which contaminants are inhibitors for biological processes in a wastewater treatment plant, because this depends on the adaptation to special contaminants of the micro-organisms working in the particular plant. Thus, the best available technique is to avoid the introduction of wastewater components into biological treatment systems when they could cause a malfunction of such systems and to treat tributary wastewater streams with relevant non-biodegradable part by adequate techniques.

- » Choice 1: Techniques that enable substance recovery:
 - Nanofiltration Or Reverse Osmosis
 - Adsorption
 - Extraction
 - Distillation / Rectification
 - Evaporation
 - Stripping

- » Choice 2: Abatement techniques without need of additional fuel, when recovery is not feasible:
 - Chemical oxidation, but care must be taken with chlorine-containing agents
 - Chemical reduction
 - Chemical hydrolysis
- » Choice 3: Abatement techniques entailing considerable energy consumption, when there is no other choice to abate toxicity or inhibitory effects or when the process can be operated on a self-sustaining basis:
 - Wet air oxidation (low-pressure or high-pressure variant)
 - Wastewater incineration
- » In cases where water supply and consumption is an environmental issue, techniques requiring considerable amounts of cooling water or wet scrubber systems for exhaust air treatment need to be assessed, such as:
 - Extraction
 - Distillation / rectification
 - Evaporation
 - Stripping
- **Biodegradable wastewater** can be treated in biological control systems, either as tributary streams in specially designed (pre)treatment systems, e.g. anaerobic or aerobic high load systems, or as mixed wastewater in a central biological wastewater treatment plant, or as a polishing step behind the central wastewater treatment plant. Thus, it is BAT to remove biodegradable substances by using an appropriate biological treatment system (or an appropriate combination of them), such as:
 - » Biological pre-treatment to relieve the final central biological wastewater treatment plant from high biodegradable load (or as a final polishing step). Appropriate techniques are:
 - Anaerobic contact process
 - Upflow anaerobic sludge blanket process
 - Anaerobic and aerobic fixed-bed process
 - Anaerobic expanded-bed process
 - Complete-mix activated sludge process
 - Membrane bioreactor
 - Trickling (percolating) filter
 - Bio filter fixed-bed process
 - » Nitrification / denitrification are useful when the wastewater contains relevant nitrogen load.
 - » Central biological treatment- In general the BAT associated with emission level for BOD after central biological treatment is < 20 mg/l. In the case of activated sludge a typical application is a low-loaded biological stage with a daily COD load of ≤ 0.25 kg/kg sludge.

Following table summarizes the treatment technology commonly adopted for soluble biodegradable particles as per Best Available Techniques Reference Document (BREF) from the European Commission.

Table no. 3.4- Bio-degradable particles / biological treatment

Parameter	Description	Environment Benefit
Anaerobic Treatment	Converts organic compounds in the absence of air to products like CH ₄ , CO ₂ , sulphides	BOD, COD
Sulphuric Compounds/ Heavy Metals	Sulphate to sulphides by SO ₄ reducing bacteria Reaction of HM with sulphides and precipitation of HM sulphides 2nd reaction to convert excess sulphide to sulphur	Sulphate, Zinc, Cadmium
Aerobic Treatment	Biological oxidation of dissolved organic substances with oxygen using the metabolism of micro-organisms	BOD, COD, Phenols, N, TSS, Turbidity (MBR)
Nitrification / Denitrification	Ammonium to nitrite and then to nitrate Anoxic de-nitrification, nitrate to nitrogen	Total N
Phosphorus (Biological)	Sequencing and producing appropriate conditions in the reactors	Phosphorous removal
Phosphorus (Chemical)	Addition of multivalent ions (Ca, Al, Fe) that form precipitates of sparingly soluble phosphates	Reduction in effluent phosphorous content

3.8 Zero Liquid Discharge (ZLD) Concept

The word ZLD in the context of wastewater management means zero discharge of wastewater from Industries. A ZLD system involves a range of advanced wastewater treatment technologies to recycle, recovery and re-use of the 'treated' wastewater and thereby ensure there is no discharge of wastewater to the environment.

A typical ZLD system comprises of the following components:

- » Pre-treatment (Physico-chemical & Biological)
- » Reverse Osmosis (Membrane Processes)
- » Evaporator & Crystallizer (Thermal Processes)

Most polluting industries such as Pharma, Pulp & Paper, Tanneries, Textile Dyeing, Chemicals, Power Plants etc. generate wastewater with high salinity/TDS. Conventional 'Physico-chemical-biological' treatment does not remove salinity in the treated effluent. The TDS content is well above the statutory limit of 2,100 mg/l and discharge of saline but treated wastewater pollutes ground and surface waters. Several States in India including Tamil Nadu are water stressed. Competing demands for water from agriculture and domestic use has limited industrial growth.

Installing ZLD technology is beneficial for the plant's water management as it encourages close monitoring of water usage and avoids wastage and promotes recycling by conventional and far less expensive solutions. However, it comes with a significant cost, both from the capital as well as at the operating cost perspective. High operating costs can still be justified by high recovery of water (> 90-95%) and recovering of several by products from the salt, however the capital costs remain a concern.

▪ **Driving Factors of ZLD in the CETPs – Example from Tamil Nadu:**

CETPs were established for some of the most polluting industries such as textile dyeing, leather tanneries, chemicals, electroplating and pharmaceutical industries. These CETPs employed conventional and well established physico-chemical, biological treatment technologies, which helped to remove the contaminants such as organics, heavy metals, dissolved and suspended solids. These systems, while treating the wastewater to reduce pollutants also generated chemical and bio-sludge. However, these failed to address the issue of salinity in these wastewaters. Typically the inorganic Total Dissolved Solids (TDS) in these wastewaters ranged anywhere between 5,000 mg/l to 20,000 mg/l. These were mostly chlorides, sulphates and other salts which increased the salinity of the receiving water bodies such as rivers, lakes and ground water and also affected large tracts of soil severely impacting agriculture.

While the textile and tannery CETPs in the state of Tamil Nadu were able to achieve considerable reduction in organics in terms of COD and BOD, difficulties were faced in achieving COD limits. The process could also not achieve reduction in salinity even after segregation of saline liquors, like soak & pickle in tanneries or dye bath liquor in textiles. The TDS in the treated effluent is ranging from 5,000 – 7,000 ppm in case of textile effluent and 10,000 – 15,000 ppm in case of tannery effluent. This resulted in continued pollution of the ground water and rivers.

Tamil Nadu is a severely water stressed state. Most rivers in the state are monsoon fed and remain dry for most part of the year. The industrial clusters, such as Textile Dyeing in Tirupur, Tanneries in Erode and Vellore, in the past have polluted large stretches of these rivers and their banks making it unfit for agriculture and human consumption.

The Hon'ble Supreme Court in October 2010, granted time to the industry to complete and operationalize ZLD system within a period of 3 months. The farmers again approached the Hon'ble High Court by filing a contempt application stating that the industry had not complied with the Hon'ble Supreme Court orders. Finally on January 29, 2011, the Bench directed the Tamil Nadu government to shut down all dyeing and bleaching units on the banks of the polluted Noyyal and to disconnect their electricity supply, holding that no unit should be allowed to reopen and operate unless it achieves ZLD. Permission was given by the Tamil Nadu Pollution Control Board (TNPCB) to Arulpuram CETP to demonstrate ZLD after carrying out modification works. Seeing the success of the operations in Arulpuram CETP, the other CETPs too decided to carry out the modifications required for ZLD. TNPCB gave permission to these CETPs for trial operations with restrictions in the effluent flow.

Meanwhile, the Tamil Nadu government announced assistance to the industry to an extent of Rs.200 crores as interest free loan to the 20 CETPs in Tirupur and TNPCB issued permission to most of the member units to re-commence operations on trial basis, with restrictions in flow volume.

'Zero Liquid Discharge' plants were targeted to eliminate any discharge of wastewater into the surrounding environment and also to promote recovery and reuse of wastewater for industrial purpose. The SPCB also insists that the R.O. reject management system should be based on thermal evaporation and does not permit discharge of rejects onto land or into deep wells. Use of solar evaporation pans is permitted only for small ETPs and for evaporator blow downs.

Several industries, large and small including ETPs and CETPs have or are under the process of establishing ZLD CETPs. Under this system, in addition to the existing physico-chemical-biological treatment systems, CETPs implemented a tertiary filtration system followed by Reverse Osmosis (R.O.). The recovered high quality water from the R.O was reused by the industry. The rejects or concentrate from the R.O was evaporated in thermal evaporators. The option of sea discharge of R.O rejects was not considered due to the increased concentration

of contaminants in the rejects during recovery of water in the R.O. and the distance of most industrial clusters in the State from the sea. Also, objections from the fishermen community and environmentalists have also constrained sea disposal.

▪ **ZLD based system for tannery industries:**

There are typical processes which are followed for achieving ZLD in the tannery industries. A schematic diagram of conventional ZLD based CETP for tanneries with MBR System for biological and Mechanical Vapour Recompression Type Evaporator (MVR-E) for brine concentration followed by MEE for thermal evaporation and crystallization of RO rejects is presented below-

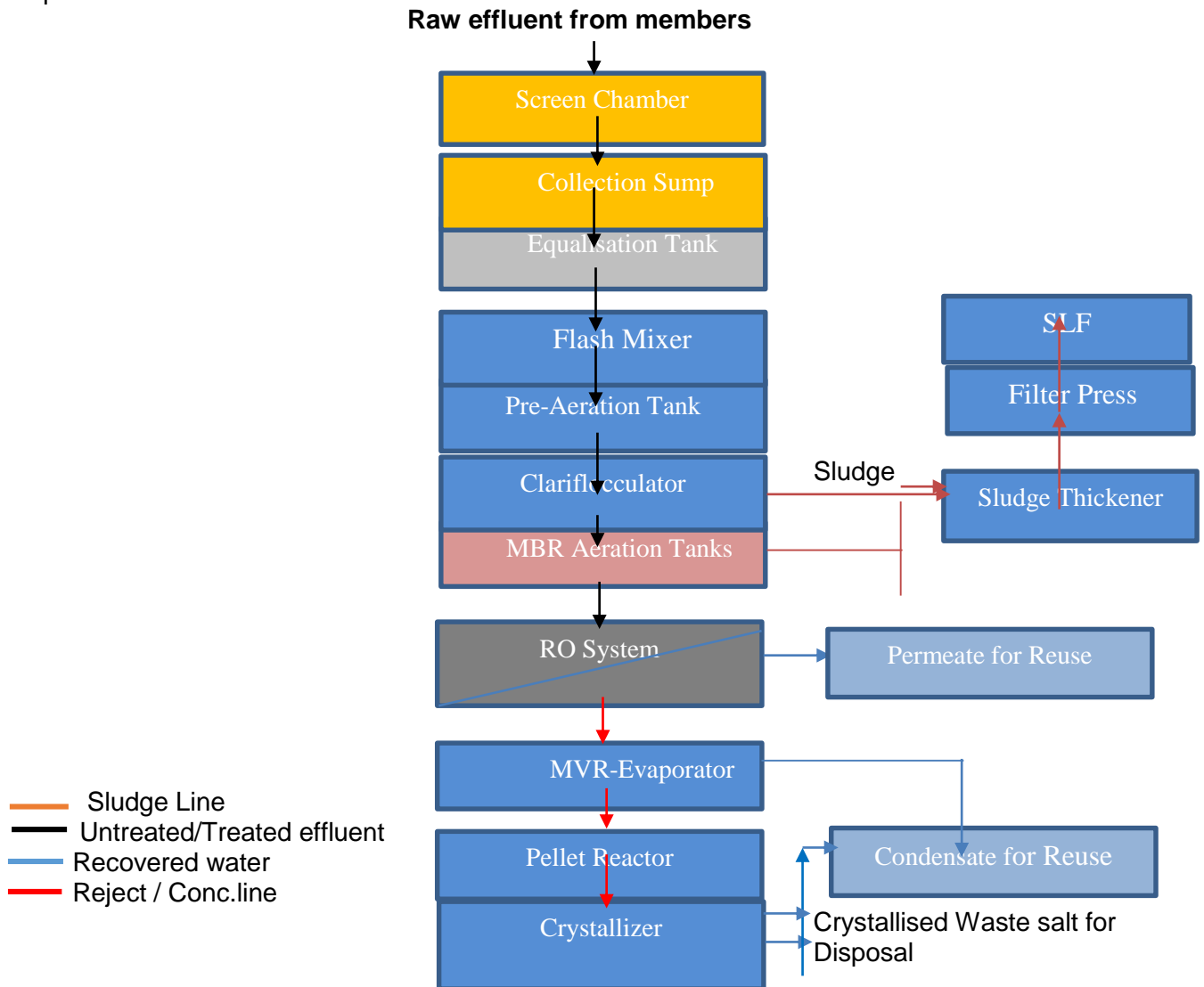

Fig. no. 3.8: Schematic of tannery based ZLD plant having MBR plant

Schematic diagram of typical ZLD based tannery CETP with conventional activated sludge process followed by UF (without MBR system) and with MEE (Without MVR-E) for thermal evaporation and crystallization of RO rejects¹⁴ is given below.

¹⁴ TWIC report on Tamil Nadu CETPs

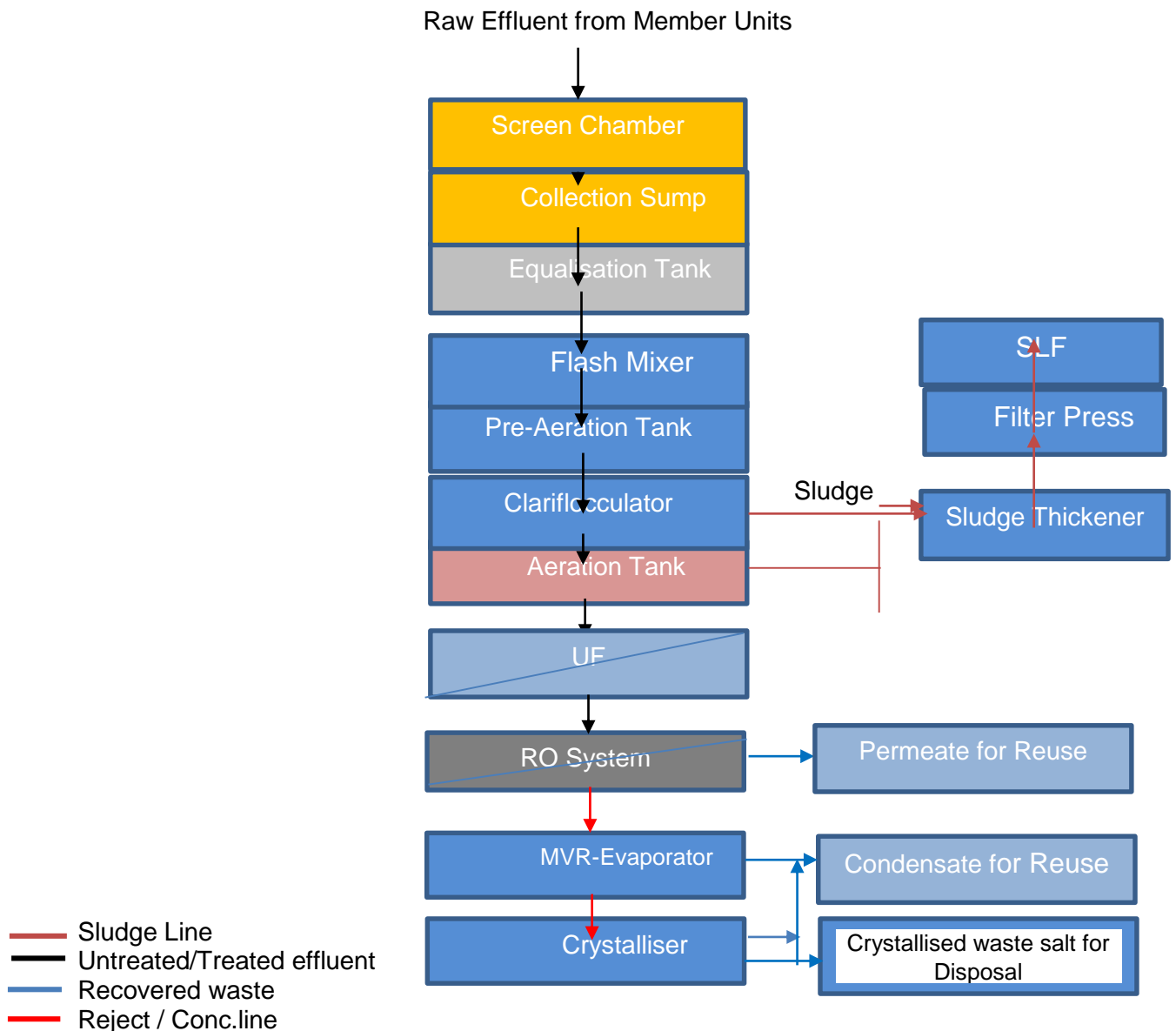

Fig. no. 3.9- Schematic of tannery based ZLD plant having activated sludge process

The effluent generated from the manufacturing process needs some preliminary treatment before sending it to CETP. Various forms of treatment exist to treat the wastewater discharged from the member units depending on the quality and quantity. The treatment is broadly classified as Preliminary Treatment, Primary Treatment, and Secondary Treatment & Tertiary Treatment. In the table no. 3.6, a summary of process employed for textile and tannery CETPs in Tamil Nadu is presented.

Table no. 3.5- Summary of treatment process employed in textile and tannery CETPs in Tamil Nadu

S.No.	Type of Treatment System	Objective
1.	Preliminary Treatment system	<ul style="list-style-type: none"> ▪ Preliminary treatment system is essential at member units to treat the wastewater properly before sending it to collection and conveyance system of the CETP. ▪ Unit processes include screening, grit chambers, oil & grease trap, sedimentation and segregation of effluent streams etc. ▪ In case of Tanneries, it is essentially to avoid choking of the sewer pipeline network and recovery of chrome liquor. ▪ Most textile CETPs do not have the need for any pre-treatment except coarse screening and employing holding tanks to reduce temperature of wastewater to ambient levels before discharge into the CETP sewer network.
2.	Primary Treatment System	<ul style="list-style-type: none"> ▪ This treatment involves equalisation and neutralisation of the effluent and prepare the effluent suitable to other downstream treatment process. ▪ Primary settling tank / Primary chemical treatment is used in some CETPs to remove TSS, Colour and insoluble BOD and COD by addition of lime and coagulants. ▪ All Tannery and Textile CETPs employ equalisation. ▪ Tannery CETPs do not require or employ any neutralization step. ▪ All Tannery CETPs employ primary chemical treatment for sedimentation and coagulation as done by some Textile CETPs. However, many textile CETPs employ a complete biological treatment to avoid sludge generation issues with primary chemical treatment.

3.	Secondary Treatment System	<ul style="list-style-type: none"> ▪ This is primarily used to remove the organic pollutant load from the wastewater. Usually aerobic and anaerobic system is used to treat the wastewater. ▪ Types of Aerobic System <ol style="list-style-type: none"> 1. Activated Sludge Process (ASP) 2. Aerated Lagoons (AL) 3. Membrane Bio Reactors(MBR) ▪ Types of Anaerobic System <ol style="list-style-type: none"> 1. Up flow Anaerobic Sludge Blanket Reactors (UASBR). 2. Anaerobic Lagoons ▪ Textile and Tannery CETPs have extensively employed Activated Sludge Process (ASP) based on extended aeration. ▪ Aerated lagoons have been employed by Tannery CETPs for pre-aeration and oxidation of sulphides. ▪ Some CETPs in both the sectors have employed MBR in lieu of extended aeration type ASP.
4.	Tertiary Treatment System	<ul style="list-style-type: none"> ▪ Lime Soda Softening System is used to reduce hardness (Calcium & Magnesium). ▪ Application of Chlorine gas for colour removal from the Textile effluents. ▪ Treatment system also includes Pressure Sand Filter, Activated carbon filter, Microfiltration (MF), Ultrafiltration (UF), Nano Filtration, Reverse Osmosis, Ion Exchange Resins for colour and hardness removal, and Ozonator systems. ▪ Various combinations of membrane filtration adopted in tertiary treatment system especially in water reuse applications as in ZLD system are: <ul style="list-style-type: none"> » Case-I : UF with RO » Case-II : MBR with RO » Case-III : UF, Nano Filtration and RO

5.	Reject Management System (RMS)	<ul style="list-style-type: none"> ▪ RMS is the final level of treatment system to handle the NF / RO rejects. ▪ Various unit processes involved in this systems are as follows: <ul style="list-style-type: none"> - Multiple Effect Evaporation (MEE): To increase the solids / salt concentration up to 300 – 400 gpl before feeding in to a salt recovery system. - Mechanical Vapour Recompression Evaporator (MVR-E): as a brine concentrator to increase salt concentration up to 100 gpl. - Adiabatic Chiller: This system is usually employed to recover the Sodium Sulphate salt from the RO rejects (esp. for Sulphate based textile dyeing). - Brine Treatment System: Patented technology was developed by TWIC (Tamil Nadu Waster Infrastructure Company) to recover a brine solution for reuse in the member dyeing units. - Solar Evaporation Pan: The mother liquor which is coming out from the salt recovery system is discharged in to SEP for natural evaporation. It is mandatory for all ZLD based CETPs in Tamil Nadu.
----	--------------------------------	--

Benefits of ZLD:

Following benefits have been observed by Industries which have implemented ZLD:

- Implementation of ZLD encourages the industry to closely monitor water usage, avoid wastages and promote recycling. For example, the textile dyeing industry changed from conventional Winches, which used more water (1: 16 liquor ratios of fabric weight to water volume) to less water consuming Soft Flow Machines with 1:8 liquor ratio and many are increasingly moving towards even lower water consuming “Air Flow Machines” with 1: 3.5 liquor ratios to increase their production, while generating lower volumes of effluent.
- The high recovery of water (> 90-95%) and the recovery of salt (at least in some textile CETPs) has mitigated the higher cost of operation of a ZLD system.
- The implementation of ZLD is expected to pave way for a more sustainable growth of the industry while meeting most stringent regulatory norms.
- Reduction in water demand from the industry by implementation of ZLD will free up water for agriculture and domestic demands.

3.9 Recycle and Reuse of Technologies¹⁵

The treated wastewater can be used for various purposes. Such reuse can be categorized as follows (Asano, 2007):

- | | |
|---|--|
| <ul style="list-style-type: none"> ▪ Agricultural irrigation <ul style="list-style-type: none"> - Food eaten raw | <ul style="list-style-type: none"> ▪ Environmental <ul style="list-style-type: none"> - Lakes and ponds |
|---|--|

¹⁵ Presentation from Dr. Christian Kazner, University of Applied Sciences and Arts, Northwestern Switzerland, at the CETP Workshop Organised by CII and GIZ at GBC Hyderabad, November 23, 2012

- Foods heated
- River flow augmentation
- Fisheries
- Landscape irrigation
 - Parks
 - Golf courses
 - Residential
- Non-potable urban reuse
 - Fire protection
 - Cleaning use
 - Toilet flushing
- Industrial reuse
 - Cooling
 - Boiler feed
 - Process water
- Potable reuse
 - Blending into reservoir
 - Piped supply
- Groundwater recharge
 - Aquifer replenishment
 - Repulsion of salt intrusion

The quality requirement varies depending on the use. There is increasing quality requirement in above categories from agricultural irrigation to potable reuse. Health based targets for treated wastewater uses in agriculture based on WHO Guideline (2006) are given below.

Table no. 3.6- WHO Guidelines on Treated Wastewater Use

Type of Irrigation	Target for Viral, Bacterial and Protozoa	Microbial Reduction Target for Helminth Eggs	Health Protection Measures
Unrestricted	≤10 ⁻⁶ DALY ¹⁶ per person per year (achievable by a 6-7 log units pathogen reduction)	≤1/L (arithmetic mean – determined throughout irrigation season for at least 90% of samples)	Wastewater treatment Health and hygiene promotion Chemotherapy and immunization
Restricted	≤10 ⁻⁶ DALY per person per year (achievable by a 2-3 log units pathogen reduction)	≤1/L (arithmetic mean – as above)	Produce restriction Food handling and preparation Cooking foods irrigation timings
Localized (e.g. drip irrigation)	≤10 ⁻⁶ DALY per person per year	(a) Low-growing crops: ≤1/L (arithmetic mean) (b) High-growing crops: (include fruits trees, olives, etc. – no crops to be picked from the soil): no recommendation	Access control. Use of personal protective equipment. Intermediate host control Reducing vector contact (bed nets, repellents) Other site specific measures

The treated effluent in centralized wastewater treatment through conventional activated sludge (membrane bioreactor) is either subjected to high technology polishing steps such as activated carbon membrane treatment and ozonation or passed through natural systems for polishing such as read bed, lagoon, slow sand filter and soil aquifer treatment. In case of decentralized wastewater treatment, after membrane bioreactor, pond treatment is followed for partial direct reuse or infiltration.

¹⁶ DALY: Disability-adjusted life years (expressed as per person per year)

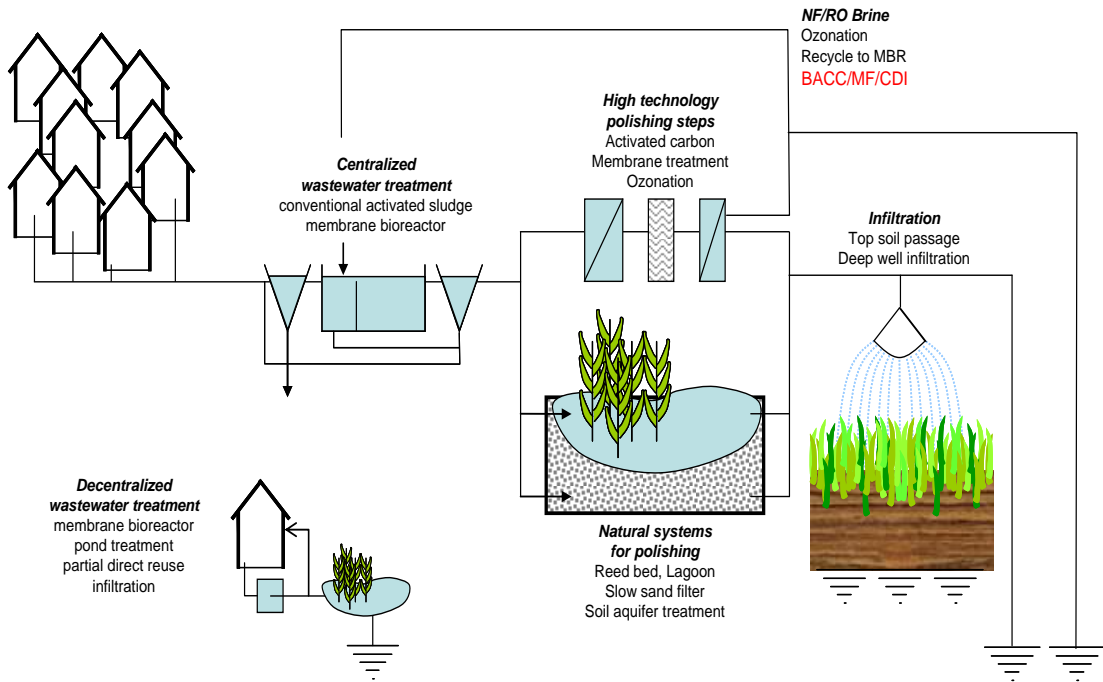

Fig. no. 3.10- Typical treatment systems for reuse of wastewater¹⁰

The quality requirements for reuse in industry depends on the type of reuse such as cooling, boiler feed, process use, cleaning, firefighting, gardening, etc. This concept is known as “water quality fit for use”. A treatment scheme for paper industry exemplifying this concept is given below.

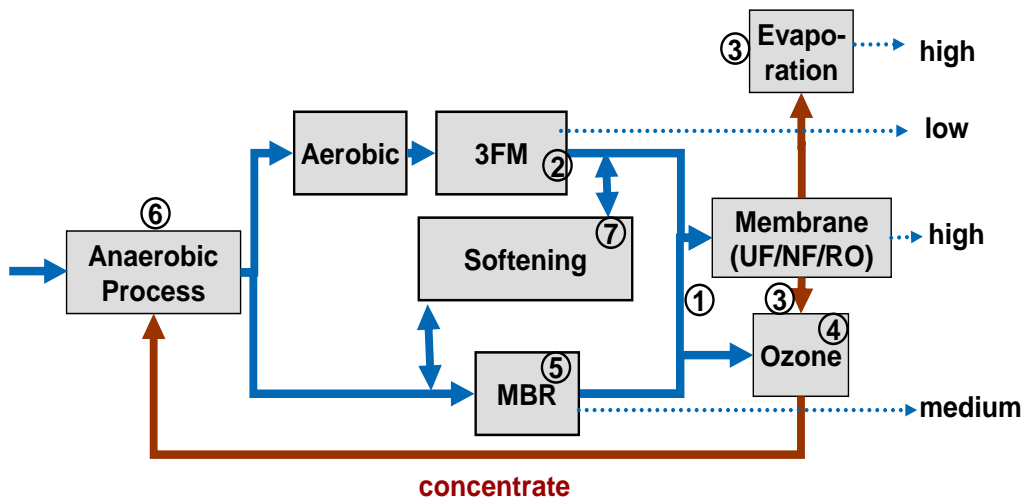

Fig. no. 3.11- Typical wastewater treatment system in paper industry for reuse (adapted from Aquafit4use, 2011)

3.10 Approach for Planning/Up-gradation of CETPs

The planning for a new CETP or up-gradation of an existing CETP is a complex and challenging procedure involving multiple stakeholders and authorities. The planning stage is of highest importance since it defines the treatment concept including the choice of technological solutions and sizing of the treatment plant.

A systematic and scientific approach for taking decisions on the measures to be implemented is very critical in attaining sustainability in the operation of the CETPs. Pilot testing and lab testing procedures must be followed before taking any decisions to make any major construction or installations of equipment etc.

▪ Main steps involved

The main steps involved in planning and execution of the physical measures in a CETP comprise:

- » conceptual planning and feasibility study,
- » preliminary and detailed design,
- » preparation of tender documents and procurement,
- » construction and supervision,
- » commissioning, and
- » project management.

A step-by-step approach is required to arrive at solutions for a CETP before their implementation. A systematic approach, including problem analysis, lab testing, pilot testing etc. is essential for planning a CETP. The general approach to be followed for setting up of a CETP is given in the figure below. The important steps involved in identifying the solutions and arriving at basic design of the CETP are given below:

- » Problem analysis
- » Identification of alternatives/concepts for wastewater treatment
- » Proofing of principles – this is required to verify that the identified concepts/solutions would work. This is done through lab testing of the solutions.
- » Parameter studies – systematic studies are required to vary a number of model parameters to arrive at optimisation of process conditions for treatment of wastewater.
- » Assessment of energy, materials and resource consumption
- » Comparison of alternatives for treatment of wastewater and arriving at preferred concept
- » Pilot tests – undertaking of pilot tests to ascertain the viability of the identified technical solutions
- » Pre-basic design of the CETP based on the identified solutions

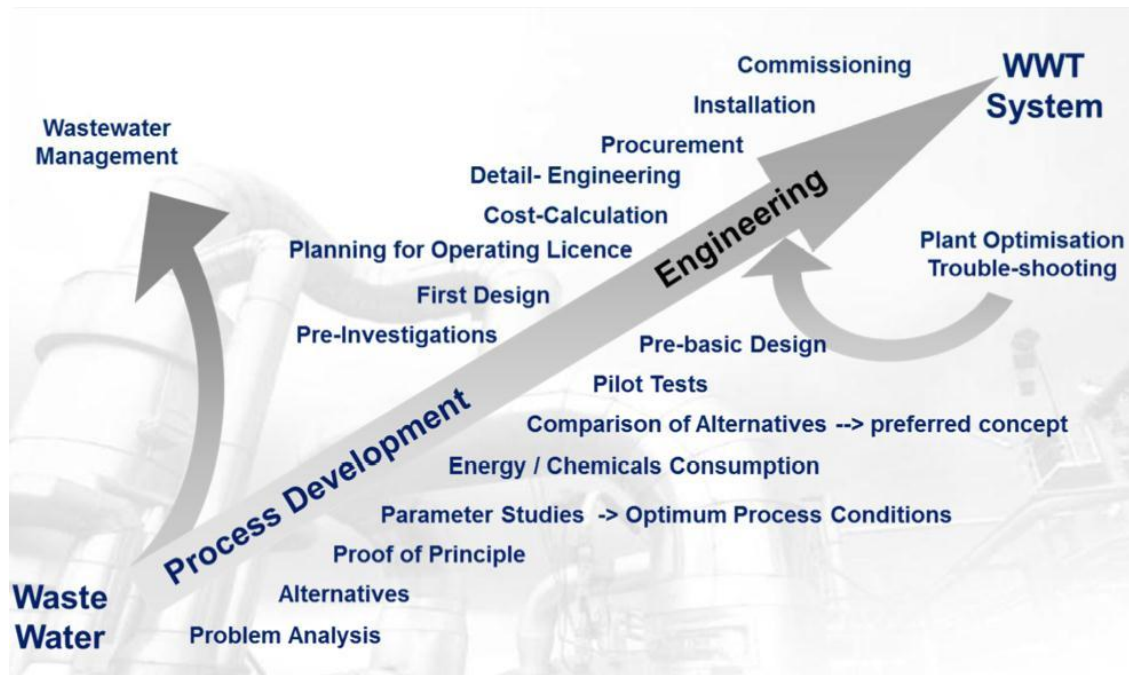

Fig. no. 3.12- Approach for setting-up wastewater treatment system¹⁷

A participatory approach will involve all involved stakeholders and avoid neglect of their interest in centralised (top-down) decision making. This will also ensure that measures at the source support the centralised solutions. An important factor in decision-making is the expected service life of the assets to be built or already operating. The time frames are of particular importance for the cost estimates (material selection, quality standards, corrosion risk, etc.) and the depreciation periods used in life cycle costing for the feasibility studies.

▪ **Up-gradation/modernisation of a CETP**

When an existing CETP has compliance issue with the required effluent standards, the up-gradation/modernisation concept should address first of address all the current shortcomings regarding the non-compliance with environmental standards. Secondly, it should consider an increase of the plant capacity, if required, with regard to the volumetric flow and load of key parameters such as COD, TDS, and ammoniacal nitrogen to accommodate future developments. The key aspects to be considered are:

- » evaluation of the present situation and a realistic diagnosis of the deficits;
- » evaluation of requirements for performance improvement; and
- » evaluation of requirements of modernisation and up-gradation.

The detailed steps involved are explained in the following chapter (4.2).

¹⁷ Presentation by Ms. Jyoti Pawar, Bayer Technology Services, Mumbai

The main steps to be followed during the conceptual phase are summarised in the figure below.

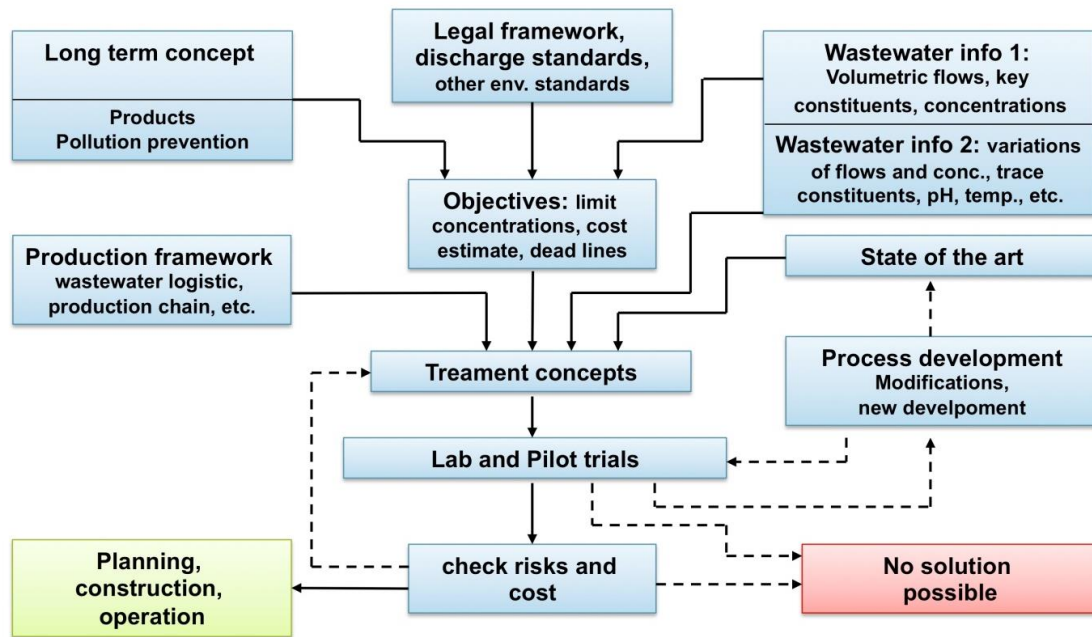

Fig. no. 3.13- Main planning steps during the conceptual phase (Melin, 2010)

▪ **Control at source at industry level**

All measures for planning of a CETP should be supported by efforts to reduce the discharge of problematic pollutants at the source. Figure below gives an overview of the decision process at the industry level on whether to send the effluent to CETP or not.

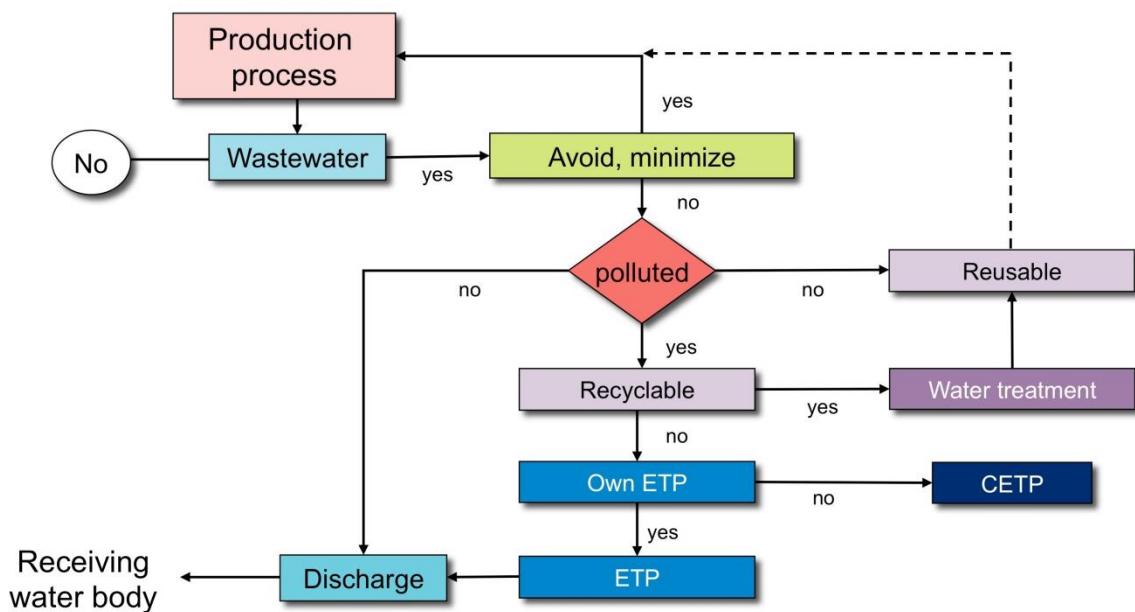

Fig. no. 3.14- Decision tree water pollution control in industries (Melin, 2010)

- **Conceptual planning and feasibility study**

This planning stage is of highest importance since it defines the treatment concept including the technological solutions with their main elements as well as the basic data relevant for sizing of the treatment plant. The technological concept has to be embedded in the socio-economic framework to identify the necessary measures for achieving financial viability, environmental sustainability and overall feasibility of the chosen approach. Thus all major decisions are to be taken during this planning stage.

The complexity of problem requires typically an adaptive, integrated and participatory approach (Segrave, 2014). The adaptive concept allows for flexibility and extendibility to achieve compliance and sufficient treatment capacity in a changing context with an increasingly uncertain future. A sufficient level of integration prevents that fragmented and simplistic approaches are applied to complex interrelated systems. A participatory approach will involve all involved stakeholders and avoid neglect of their interest in centralised (top-down) decision making. This will also ensure that measures at the source support the centralised solutions. An important factor in decision-making is the expected service life of the assets to be built or already operating. Table no. 3.7 illustrates typical depreciation periods of the different elements of a water and wastewater management system. The time frames are of particular importance for the cost estimates (material selection, quality standards, corrosion risk, etc.) and the depreciation periods used in life cycle costing for the feasibility studies.

Table no. 3.7- Average technical service life of different types of assets (Segrave, 2014)

Type of Asset	Indicative Technical Service Life (years)
Water intake / abstraction	40
Civil engineering / buildings	40
Mechanical components	25
Electrical components	20
Process automation facilities	10
Transport pipelines	60
UF Membranes / HF	8
Membranes NF / HF	5
Seawater RO Membranes	4
Replacement activated carbon (new)	2
Replacement activated carbon (regeneration)	15
Other (filter sand etc.)	10

When developing a concept for an existing plant the decision process influenced by a sound evaluation of the present situation and a realistic diagnosis of the deficits as well as requirements for performance improvement, modernisation and upgradation. The following list gives an overview of key actions during the initial planning phase:

Acquisition of basic data

- Acquisition of basic data (inlet, outlet, concentrations, volumes, energy demand, waste production)
- Compilation of existing documents (design reports, plant documentation, internal/external reports, previous studies, population forecasts, industrial developments)
- Legal standards and requirements (present and future developments)
- Projection of the future quantities and qualities of the effluents to be treated

Problem analysis and identification of present shortcomings

- Visual inspection (overall performance, tear and wear, maintenance, etc.)
- Observations of staff and administration/management
- Review of design
- Survey of previous measures and approaches that failed
- Recalculation of unit processes
- Compare design values to present requirements
- Identification of defaulting units
- Diagnosis of main technical and operational issues

Development of action plan

- Identify required operational measures for immediate trouble shooting
- Identify unit processes and integrated approaches (e.g. source control vs. end-of-pipe methods) to meet present and future requirements in wastewater treatment and waste management
- Compilation of potential treatment trains
- Define requirements for lab testing and pilot testing (proof of principle, parameter studies, etc.)
- Develop action plan and timeline for operational, technical and supportive measures such as trainings
- Initiate corrective measures (operation, etc.)
- Initiate additional studies (lab, pilot trials)
- Extension concept

Master plan

- Compile and evaluate of data for development of industries and production sites
- Identify numbers and locations of effluent treatment facilities (production sites, clusters of similar factories, common effluent treatment plants)
- Define treatment standards to be achieved
- Evaluate alternative wastewater management concept (centralised vs. decentralised treatment, combinations, clusters, etc.)
- Develop risk management concept (redundancies, energy supply, waste disposal, etc.)
- Develop master plan

Conceptual design and feasibility study

- Evaluate effect of initial corrective measures in existing plants

- Identify potential technology providers and availability of units in lab, bench and pilot scale
- Execute lab and pilot tests (onsite and/or in commercial labs)
- Define optimum process conditions based on executed tests
- Identify demand of energy and chemicals and waste production
- Comparison of alternative options based on cost estimates
- Compare potential treatment trains achieving same level of compliance (using cost-benefit analysis, life cycle costing, life cycle assessment, etc.)
- Identify and evaluate socio-economic boundary conditions
- Development of technical extension concept
- Conduct feasibility study (evaluation of technical, economic and environmental dimension of the project)
- Develop implementation concept (short, medium, and long term)

Planning and construction

The approach for the planning and construction phases depends mainly from the overall management and financing concept, i.e. the level of involvement of private and public funds, who owns and operates the facilities, etc. Generally all forms of public-private-partnerships and forms of financing, construction and operation are feasible. Further information is available from the GPP (Green Public Procurement Criteria for Waste Water Infrastructure) published by the European Commission (EC, 2013).

4 Business Models for CETPs

Smooth functioning of CETP is very much linked to the kind of business model adopted by the CETP. Several business models are in practice for the CETPs. Most commonly used models are full public ownership, full private ownership and Public Private Partnership. Brief details are given below.

4.1 Full Public Ownership

The government agencies, such as the State Industrial Development Corporations, finance construction and operate the plant. These agencies own the industrial estates and are responsible for their infrastructure and services. The advantages in this model are:

- Full control over necessary management and technical expertise that is required for planning, erection and operation & management.
- Because the public body maintains other services for the industrial estate, such as water, power, roads and drainage, the operation of a CETP could conveniently become part of the overall services being offered to industries.
- Enforcement of legal and financial obligations on the individual industries may be less difficult than by other arrangements. The enforcement may also be enhanced through the ease of coordination and cooperation with other government agencies such as water and electricity boards.

The disadvantages with this model are:

- Potential inefficiency and ineffectiveness of the public sector enterprises.
- Environmental regulatory agencies may be more reluctant to impose standards and enforce compliance on another government agency/public body.
- Slow response in case of trouble shooting, lack of qualified staff etc.

4.2 Full Private Ownership

The fully private ownership includes two types of arrangements:

- First is where an outside agency specialising in operating effluent treatment plants is contracted to establish and manage the CETP. In order to attract outside agencies, a minimum profit must be guaranteed to the agency to enter into contract. This contract arrangement is not a very common in India but there is a trend, however for industries to operate treatment plants on contract basis where public sector owns and constructs the plant and private sector is contracted to manage and operate the facility.
- Secondly, a company is formed as a separate entity and industries association or individual units within that estate would come forward for the formation of such a company under Section 25 of the Companies Act or as a trust or as a society. It is beneficial that the industries producing waste are directly involved in the financial and legal aspects in the CETP company, as their active involvement in the operation and management of CETP will increase the success of a CETP.

For control over planning, appointment of private operator, and O&M of the CETP, often a Special Purpose Vehicle is formed representatives of individual industries, industries association and industrial park management.

Private bodies that take up construction and operation of the CETP, make investments. The company would recover the capital costs, operating and maintenance expenses and a profit through a charge levied on individual wastewater producers in accordance with the volume and composition of the wastewater treated. The operating company enters into contracts with individual wastewater producers so that legal action can be initiated in case of breach of contract. The legal relationship between the operating agency and the user of CETP is well defined by a contractual arrangement between the parties. This company can incorporate individual industries and industrial association as shareholders.

The private ownership often works on BOO (Build Own, Operate) model, in which project ownership of the project remains usually with the private company. The private company gets the benefits of any residual value of the project. A BOO scheme involves large amounts of finance and long payback period.

The disadvantages of this kind of partnership are:

- Monopoly by the private operator;
- Arbitrariness in user charges;
- Lack of control on defaulting industries by the operator; and
- Risk of quality of services by the operator.

4.3 Public Private Partnership

Under the public-private partnerships, there are infrastructure development models wherein a private entity receives a concession from the private or public sector to finance, design, construct, and operate a facility stated in the concession contract. This enables the project proponent to recover its investment, operating and maintenance expenses in the project. The following models under PPP are used in the CETP projects.

► BOT:

In the Build/Own/Operate/Transfer (BOT, BOOT) arrangement, the private sector designs and builds the infrastructure, finances its construction and owns, operates and maintains it over a period, often as long as 20 or 30 years. This period is sometimes referred to as the "concession" period. Such projects generally provide for the infrastructure to be transferred to the government at the end of the concession period. During the concession period, the private party is entitled to retain all revenues generated by the project and is the owner of the regarded facility. The concession period is determined primarily by the length of time needed for the facility's revenue stream to pay off the company's debt and provide a reasonable rate of return for its effort and risk.

BOT finds extensive application in the infrastructure projects and in public-private partnership. In the BOT framework a third party, for example the public administration, delegates to a private sector entity to design and build infrastructure and to operate and maintain these facilities for a certain period. During this period the private party has the responsibility to raise the finance for the project and is entitled to retain all revenues generated by the project and is the owner of the regarded facility. The facility will be then transferred to the public administration at the end of the concession agreement without any remuneration of the private entity involved. The concession period is determined primarily by the length of time needed for the facility's revenue stream to pay off the company's debt and provide a reasonable rate of return for its effort and risk.

Calcutta Leather Complex (CLC): M.L.Dalmiya & Co Ltd (MLD) on BOT basis. CETP designed with the support of UNIDO.

► **BOOT:**

During the concession period, the private company owns and operates the facility with the prime goal to recover the costs of investment and maintenance while trying to achieve higher margin on project. The specific characteristics of BOOT make it suitable for infrastructure projects for the social welfare but are not attractive for other types of private investments.

Ludhiana CETP: 115 MLD (proposed) in Ludhiana is on Build-Own-Operate-Transfer (BOOT) basis. Industries are from the Punjab Dyers Association. The role of IL&FS is preparation of DPR, PMC and O&M.

Tarapore CETP, Maharashtra: M/s Superklean Env. Enggs. Pvt. Ltd., M/s Klean Env. Consultants Pvt. Ltd., M/s. Jog Engineering Ltd. (an ISO 9001 Certified Construction Company) and M/s Ashta Siddhi Constructions Pvt. Ltd. formed the CETP on BOOT basis.

► **BOO:**

In a BOO project ownership of the project remains usually with the project company. Therefore, the private company gets the benefits of any residual value of the project. A BOO scheme involves large amounts of finance and long payback period. Some examples of BOO projects come from the water treatment plants. These facilities are run by private companies to process raw water, which is supplied by the public sector entity and then filtered water is returned to the public sector utility to deliver to the customers.

PETL (Patancheru Enviro Tech Ltd.) was developed on BOO basis. The Andhra Pradesh Industrial Infrastructure Corporation Ltd. (APIIC) built, owned and operated the CETP initially, and later transferred to PETL. Eventually, PETL got installed MBR, ultra filtration and membrane bioreactor (MBR).

There are different models on which public private partnerships are working. One another variation could be tripartite arrangement which has three parts:

- Ownership and financing of CETP by the public body (e.g., state industrial development corporation).
- The public body would have a contract with a private company to design, construct, and operate CETP for a designated number of years. The company would recover operating and maintenance expenses and a profit from the charge levied on individual wastewater producers in accordance with the volume and composition of the waste.
- The operating company would enter into contracts with individual waste producers so that legal action can be initiated in case of breach of contract. This company can incorporate individual industries and Industrial association as shareholders. The legal relationship between the operating agency and the user of CETP must be well defined by a contractual arrangement between the parties

The SPV or the society or the public body, as the case may be, selects and enters into a contract with a private company to design, construct, and operate CETP for a designated number of years. The company would recover the capital costs, operating and maintenance expenses and a profit through a charge levied on individual wastewater producers in accordance with the volume and composition of the wastewater.

Under the public-private partnership model, there are different infrastructure development models wherein a private entity receives a concession from the private or public sector to finance, design, construct, and operate a facility stated in the concession contract. This enables the project proponent to recover its investment, operating and maintenance expenses in the project.

Formulation of the appropriate institutional and jurisdictional arrangements for ownership and operation of a CETP is as important as a good engineering design. For overseeing a CETP, a Special Purpose Vehicle (SPV) could be formed under an appropriate statute with representation from the key stakeholders of the CETP. A legal agreement is entered into between the SPV and its member units clearly delineating their relationship and mutual obligations.

In additions to above models, other models ranging from the least to the most private involvement are¹⁸:

- **Full public ownership**, in which the government finances construction and operates the facility. The type of capital financing and funding of operations determine the extent to which the facility is subsidized or pays for itself.
- **Contract services**, in which the public sector owns, designs, and constructs the facility and the private sector is contracted to manage and operate the facility.
- **Turnkey facility**, where the public sector owns and finances a facility that is designed, constructed, and operated by the private sector. Few examples are-
 - ➔ Kagal CETP Pvt. Ltd., Maharashtra: A turnkey project of 10 MLD has been done by a private company at Kagal Industrial Area. In this facility, the Maharashtra Industrial Development Corporation (MIDC) is the facilitator and the Maharashtra Pollution Control Board (MPCB) is the monitoring authority.
 - ➔ **CETP at Apparel Park at Doddaballapura** is on turnkey basis including operate and maintain the treatment plant for a period of 3 years.
 - ➔ **Pallavaram CETP (PTIETC)** is set up on Turnkey basis and implementation of CETP by a private company.
- **Developer financing**, which involves the financing of construction or expansion of a facility by the private sector in exchange for the right to build houses, stores, or industrial facilities.
- **Privatization**, which results in private ownership, construction, and operation of a facility. The public sector provides some financing based on a public decision to provide services.
- **Merchant facilities**, which are fully private; the private sector decides to provide the service and therefore finances, owns, constructs, and operates the facility.

4.4 Special Purpose Vehicle (SPV)

¹⁸ Source: (<http://www.bvsde.paho.org/enwww/fulltext/resipeli/preven/web/files/pdf/vol1/sec7.pdf>)

In order to manage a CETP, a Special Purpose Vehicle (SPV) is registered under an appropriate statute. A legal agreement between the SPV and its member units clearly delineating their relationship and mutual obligations should be executed and reflected.

Key features in SPV model are:

- Capable of acquiring, holding and disposing of assets.
- An entity, which would undertake only the activity of asset securitisation and no other activity.
- Must be bankruptcy remote, i.e., the bankruptcy of Originator should not affect the interests of holders of instruments issued by SPV.
- Must be bankruptcy proof, i.e., it should not be capable of being taken into bankruptcy in the event of any inability to service the securitised paper issued by it.
- Must have an identity totally distinct from that of its promoters/ sponsors/constituents/ shareholders. Its creditors cannot obtain satisfaction from them.
- Must be tax neutral, i.e., there should be no additional tax liability or double taxation on the transaction on account of the SPV acting as a conduit.
- Must have the capability of housing multiple securitisations.

Company as a SPV: Structuring the SPV as a Company under the Companies Act, 1956, has certain legal and regulatory issues as well as entity level taxation issues. A company formed under the Companies Act, 1956 cannot be bankruptcy proof since under Section 433 of the Companies Act can wind it up. A Company as SPV can remain bankruptcy remote if there is true sale from Originator of SPV.

Brief about a few of the SPVs that are managing CETPs in India are presented below-

- ▶ **PETL:** SPV is registered as a society on “No Profit, No Loss”. They are having SPV and Board of 7 members for management and operation. They treat the wastewater and sell the treated effluent. The received amount is used in O&M (operation and maintenance) and shared by industries.
- **Vatwa CETP, Gujarat** is run by the Association of industries at Vatwa. The SPV is registered as a Society.
- **Butibori CETP Pvt. Ltd., Maharashtra:** It is an SPV of M/s SMS Infrastructure Ltd. and Butibori Manufacturers Association. The objective of this company is to treat the effluents generated by the Industries in the MIDC Industrial Estates. In this facility, MIDC is the facilitator and the Maharashtra Pollution Control Board is the monitoring authority. Capacity of CETP is about 5 MLD.
- **SMS Waluj CETP Pvt. Ltd., Maharashtra:** It is an SPV of M/s SMS Infrastructure Ltd. And Waluj Industrial Association. The CETP handles wastewater from the Waluj Industrial Area. In this facility MIDC is the facilitator and MPCB is the monitoring authority. Capacity of CETP is about 10 MLD.
- **Pallavaram CETP (PTIETC):** The Pallavaram CETP, joining with other six other CETPs in Tamil Nadu, formed an SPV by name M/s Chennai Environmental Management Company of Tanners (CEMCOT) for implementation of the project.

- **Naroda CETP:** SPV registered as a Company under Section 25 of the Companies Act 1956.
- **Vatva CETP:** It is managed by a Cooperative Society named The Green Environment Services Cooperative Society Limited formed by the member units of GIDC Estate, Vatva.

4.5 Trustee Company as SPV ¹⁹

The Trustee Company is similar to a Trust with only the role of the Trustee being undertaken by a Company. With individuals becoming increasingly averse from acting as Trustees, a Company may act as the Trustee. The characteristics of the Trustee Company:

- A Company under the Companies Act, 1956 which would act as the SPV.
- It would acquire the receivables by assignment from the Originator and hold them in its capacity as Trustee.
- The Trust Deed should ensure that the Company can act as the Trustee and also hold in Trust separate tranches of receivables pertaining to different transactions
- The SPV/Trustee are not liable for the good performance of the assets.
- The administration of the SPV's assets for any transaction may be subcontracted back to the Originator or to any other servicer through an Administration Agreement describing the different tasks to be performed by the Originator (in its capacity as Administrator).

A few examples of Trustee Company are:

- **Pali CETP Maharashtra** is managed and maintained by the Pali Water Pollution Control Research Foundation (PWPCRF) Trust.
- **Balotra CETP** is managed by Balotra Water Pollution Control and Treatment Trust Balotra, Rajasthan.

4.6 Role of Industrial Infrastructure Corporations

The industrial infrastructure corporations responsible for development of industrial estates/parks can play important role in planning/establishing of CETP. Their role includes:

- Initiation of a process for setting up of CETP/STP in the existing as well as new industrial parks on need basis.
- Earmarking of required land for CETP/STP under common amenities on lease basis or nominal lease rentals.
- Facilitating to tap the funds for CETPs/STPs under various schemes of both Central and State Governments.
- Facilitating industry associations/member industries in implementing CETP scheme.
- Facilitating formation of SPV/JV Company by member industries of industrial estate/park, preferably as a not- for- profit Company.

¹⁹ Source: (<http://rbidocs.rbi.org.in/rdocs/PublicationReport/Pdfs/10796.pdf>)

- To enter into legally binding agreement with SPV clearly delineating their relationship, mutual obligation and defining roles and responsibilities of each of the parties.
- While industrial infrastructure corporations facilitate laying of pipeline/sewer from individual industries to CETP, the responsibilities of disposal pipeline from CETP to outlet for discharge of effluent should be of SPV/JV.
- To take necessary steps to constitute “Tariff Committee” in consultation with SPV/JV and the operator of CETP for determining and amending from time to time, as may be necessary, the tariff or user charges to be paid by member industries for treatment of their wastewater.

4.7 Financing Aspects

The capital costs for a CETP typically include:

- » land;
- » equipment and machinery;
- » civil, electrical and mechanical works;
- » administrative building;
- » laboratory and laboratory equipment for analysis including instrumental analysis;
- » approach road, internal roads, fencing;
- » DG sets;
- » piping (preferably High Density Poly Ethylene (HDPE) of suitable pressure rating);
- » instrumentation for monitoring of flow, D.O., TOC, TDS, VOC; and
- » conveyance system etc.

The operational and management costs typically include:

- » salaries and benefits to staff, including bonus, medical reimbursements, provident fund;
- » electricity costs;
- » fresh water costs;
- » transportation charges of effluent, if applicable;
- » sampling and analysis costs of effluent;
- » CETP maintenance and repairs costs, including costs of spares;
- » sludge disposal charges;
- » laboratory chemicals and glassware;
- » chemicals (consumables) like lime, alum, poly electrolyte etc. used in CETP;
- » electrical spares; and
- » depreciation costs.

The existing central/state assistance as per MoEF CETP scheme is as below:

- » Central assistance (subsidy) of 50% of the total project cost subject to a ceiling of Rs. 20 crore without ZLD and Rs. 40 crore for projects with provision of ZLD.
- » The Central assistance shall also be restricted to Rs. 1.5 crore per MLD for a CETP project without ZLD.
- » The State share shall be 25% of the total project cost.
- » The project proponent's contribution shall be 25% out of which at least 15% shall be the contribution of the project proponent and the balance could be raised by the concerned project proponent from loan from Banks/Financial Institutions

5 Management Models for CETPs

5.1 Independent O&M Agency

Independent O&M agency is perceived to be more efficient from the overall co-ordination point of view. However, since CETPs adopt variety of specialised technologies, at times it becomes difficult to manage by a single agency unless they possess experts to deal with each of these technologies. Tamil Nadu is one state, which has been insisting the CETPs to appoint a single independent operator for carrying out the O&M of the entire facilities of the CETP.

However, most of the CETPs have been operating on their own or through local and other companies for different sections. The Government of Tamil Nadu, while sanctioning the interest free loan to the CETPs, it had clearly stipulated that the CETPs are not allowed to operate on their own and have to appoint a professional independent O&M agency for the entire facilities of the CETPs for a period of 15 years. However, majority of the CETPs are operating with multiple O&M agencies. Typical organisational chart is given below.

5.2 Multiple O&M Agencies

As mentioned above, majority of the CETPs are operated by multiple O&M operators, i.e. separate / individual operator for Pre-treatment section, RO Section and Evaporator section. Some sections are operated by the CETPs themselves and some sections through outside contractors.

Issues with having multiple O&M agencies:

- Problems are foreseen in coordination between performances of different sections in terms of input/ output quality and recovery in each section. Contractual disputes and blame game between the O&M operators and the CETP are seen in many cases.
- It will be very difficult to prove or substantiate or hold a particular O&M agency responsible for any failure in performance of a particular component.
- Overall CETP optimisation will be difficult.
- It will be difficult for the regulatory authorities to deal with multiple O&M agencies for each CETP.

5.3 Overview of Business & Management Models in Tamil Nadu

Different combinations of business and management models have been adopted across the country. The following section gives a brief over view about the business and management model followed in Tamil Nadu.

In Tamil Nadu, the Textile and Tannery sectors based CETPs are functioning based on the full private ownership model. Under this model, the CETPs have collectively invested 25% (typically) of the initial project cost and the balance 75% was received as grant from the state and central governments under various schemes of the Ministry of Environment & Forests, Ministry of Commerce (ASIDE, ILDP schemes) etc. The industry's contribution of 25% was through equity (15%) from their member units and loan through banks.

Out of the 18 textile CETPs in Tirupur, 9 CETPs with total capacity of ~ 53 MLD adopting ZLD technology were established by forming 3 No's Special Purpose Vehicle (SPV) companies,

namely, i) Noyyal SPV, ii) Tirupur SPV, and iii) Mangalam-Eastern SPV. The other CETPs have been established by the dyeing and bleaching units in and around a particular location and registered the CETPs as a separate company.

In the Tannery sector, two SPVs were formed, namely the Ambur Economic Development Organisation Ltd (AEDOL) catering to three CETPs (VANITEC CETP at Vaniyambadi, AMBURTEC, at Thuthipet, Ambur and Maligaithope CETP at Ambur) and the Chennai Environmental Management Company of Tanners (CEMCOT) catering to the remaining 6 tannery CETPs.

Though the CETPs are functioning as a Private Ownership model, both Central and State Governments have extended financial assistance by way of grants/subsidies to the CETPs. The State Government has also sanctioned an interest free loan to the textile CETPs for carrying out the modification works for achieving ZLD.

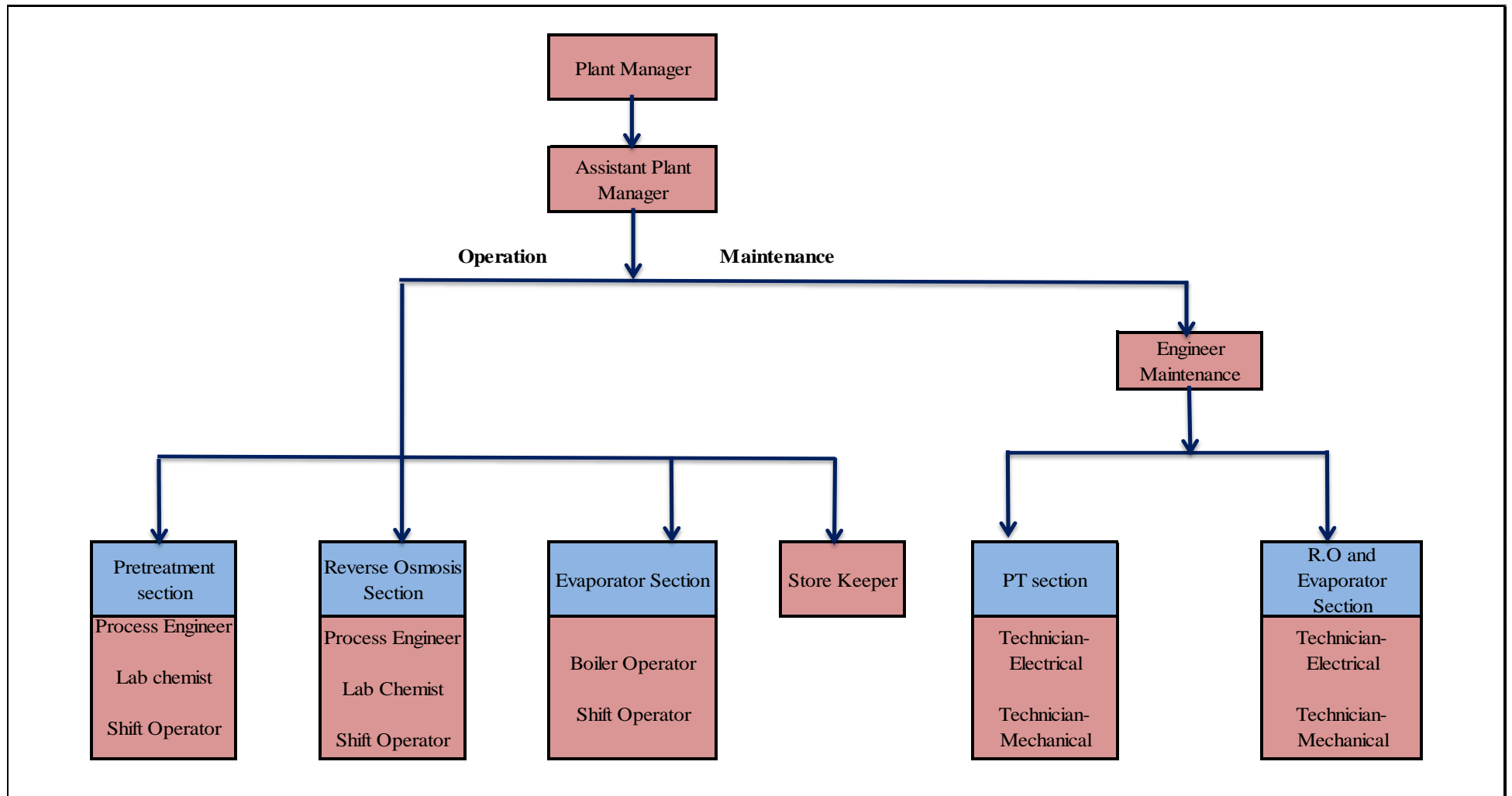

Fig. no. 5.1- Typical organisation chart of TWIC CETPs

6 Case Examples

6.1 Rayapuram Common Effluent Treatment Plant

» **About:**

The Rayapuram Common Effluent Treatment Plant is situated near the bank of Noyyal River in the main city of Tirupur in Tamil Nadu. Rayapuram Common Effluent Treatment Plant Private Limited Company is registered under the Companies Act, 1956. The processing capacity of this CETP is 5.5 MLD, which caters to the needs of 19 member dyeing units.

» **Collection & conveyance system:**

Three separate pipeline networks of 5 km length have been constructed between the CETP and the member units for conveyance of, a) raw effluent collection, b) recovered water, and c) brine solution.

Electro Magnetic Flow Metering (EMFM) system has been installed for measuring flow. The entire system is monitored through PLC/SCADA, which is connected with the website.

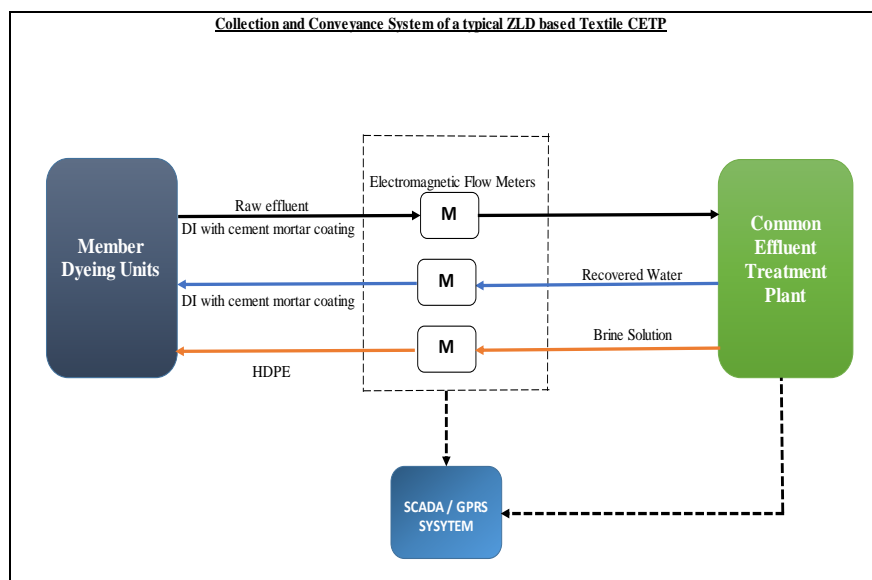

Fig. no. 6.1- Collection and conveyance system

» **Treatment process:**

Details of the unit operations in the CETP are briefed in the table below.

Table no. 6.1- Treatment system

Unit Process	Brief Description
Raw effluent collection and recovered water conveyance systems	Raw effluent discharged by the member industries is being collected in the collection well and pumped to the CETP. The treated water and brine solution recovered in the CETP are distributed back to the member units. The quantity of raw effluent, recovered water and brine solution are quantified by the electromagnetic flow meters installed in the member units.

Unit Process	Brief Description
Equalization	The raw effluent received from the dyeing industries is homogenized to get uniform characteristics. To keep the contents of the tank always in the mixed condition, flow jets and flow mixers have been installed in the tank.
Activated Sludge Process	Extended aeration type biological oxidation tanks are provided with necessary air blowers, diffusers and flow makers. The main objective is reduction of organic load (COD & BOD) and further reduction of TSS, Colour and Turbidity.
Chlorine Contact System	Reduction of colour is achieved by sending effluent through the Chlorine contact system. Also, the system helps increase the performance of the decolourant resin filter.
Ultra Filtration	Helps in removal of total suspended solids, colloidal organic materials and silt (SDI <3). Helps protect Reverse Osmosis membranes and achieve higher recovery. Also, helps maintain performance of resin filters.
Decolourant Resin Filter	Removes organics and reduces colour.
Softener Resin Filter	Reduces Total Hardness.
Reverse Osmosis (4 Stages)	Four stage RO system is designed to get overall recovery of 88% of product water by removal of dissolved inorganic salts. First and second stages are loaded with brackish water (BW) membranes and third and fourth stages are loaded with sea water (SW) membranes.
Additional stage of Reverse Osmosis	Helps in further volume reduction of R.O rejects and brine discharge through resin filter (BDTRF) waste/ brine, and further recovery of water (under implementation).
Mechanical Vapour Recompression Evaporator (MVR-E)	For increasing the solids concentration from 6% to 9% w/v and further recovery of water.
Falling Film Evaporator (FFE)	To increase the solid concentration from 9% to 22% w/v.
Adiabatic Chiller	To recover sodium sulphate from the FFE concentrate as Glauber's salt.
Centrifuge (Pusher Type)	To separate the salt and mother liquor.
Forced Circulation Evaporator (FCE)	To concentrate and recover the water from mother liquor. FCE concentrate is discharged to solar pan for natural evaporation.



Lifting Pump station



Storage and Homogenisation Tank



Biological Oxidation Tank



Secondary Clarifier

Fig. no. 6.2- Photographs of treatment components of Rayapuram CETP

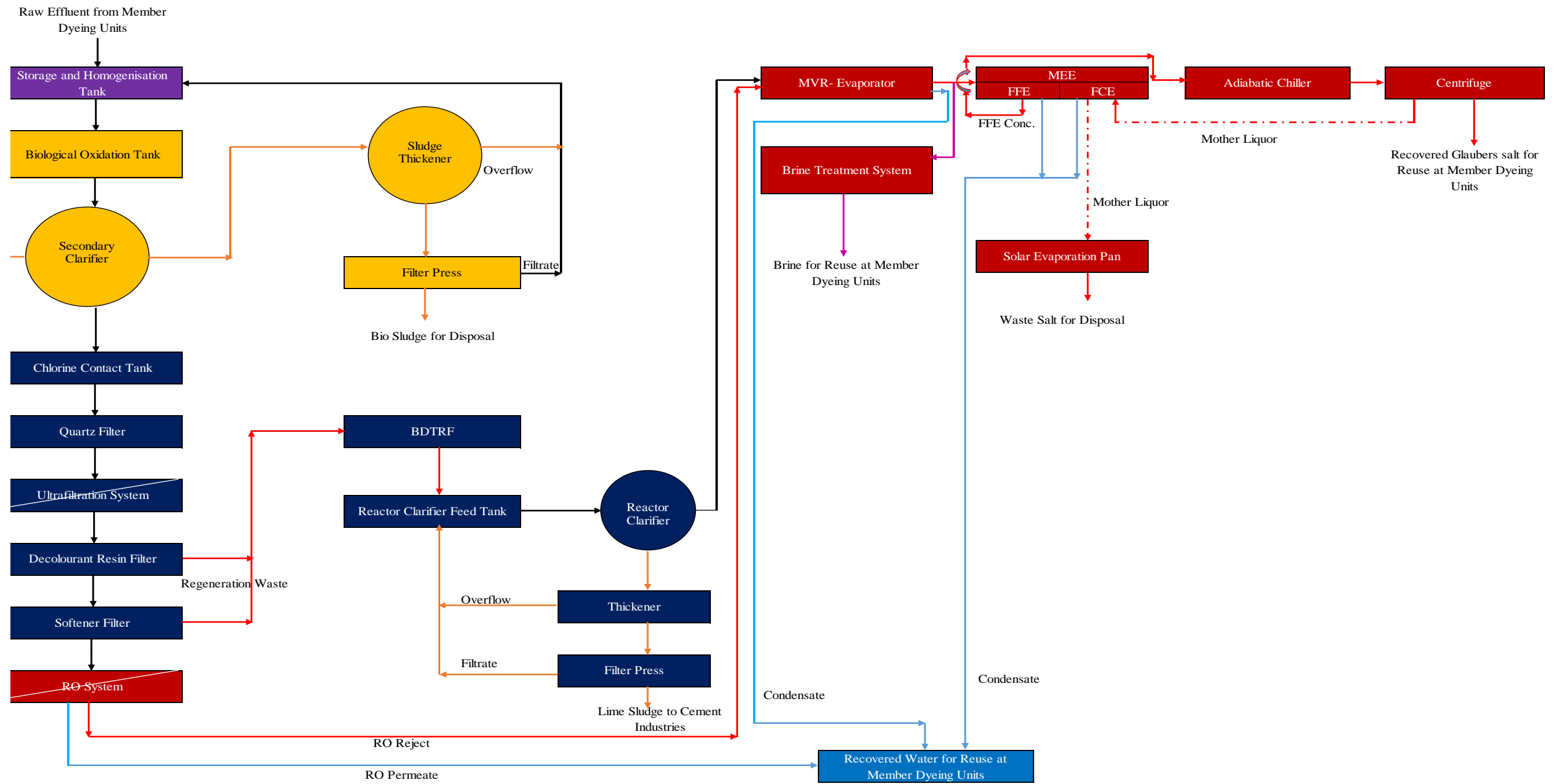

Fig. no. 6.3- Process flow diagram for Rayapuram CETP

» **Solid waste management:**

The TNPCB has directed the CETP for disposal of the solid wastes in TSDF facility. The CETP have entered into an MOA with a local cement plant for usage of the chemical sludge at their factory. Details of the waste generated are given below.

- » Biological sludge is generated from the secondary activated sludge process. This sludge has 75% organic and 25% inorganic content.
- » Regeneration waste from decolourant resin filter and softener filter is fed to reactor clarifier with dosing of lime and soda ash to remove colour and hardness. This stream generates lime sludge.

» **Financing:**

Funding sources for completion of this project are presented in the table below.

Table no. 6.2- Financing pattern - Rayapuram CETP

Source	Means of Funding	Original Project Cost (Rs. Crore)	Additional Project Cost (Rs. Crore)	Total Cost (Rs. Crores)	Overall %
Go/GoTN	ASIDE Grant – Gol	4.80		35.77	54%
	Special subsidy – Gol/GoTN	20.30			
	Interest Free Loan-GoTN		10.67		
Industry	Promoters Contribution	7.60	6.13	13.73	21%
Loans	Loan from Bankers	14.10		14.10	21%
TWIC	Investment through Optionally Convertible Debentures (OCD)	2.50		2.50	4%
	TOTAL	49.30	16.80	66.10	100%

Source: Noyyal SPV, Tirupur

The operations & maintenance costs are shown in the table below. The present cost is higher due to the lower effluent handling capacity of this CETP (avg.1,400 cu.m/day) against the designed capacity of 5.5 MLD.

Table no. 6.3: O&M cost - Rayapuram CETP

S.No.	Item Description	Approx. O&M Cost (Per cu.m.)
1.	Fixed Cost (Power, Manpower Cost, Replacement, Standard Maintenance, Lab Chemicals, Admin & Statuary)	Rs. 287
2.	Variable Cost (Power, Diesel, Chemicals, Cartridge Filter, Sludge Handling Charges, Maintenance & Firewood Cost)	

- Note:
1. Sludge & waste salt disposal cost are not included in O&M cost
 2. Current utilization capacity is only 30% and project modifications are ongoing. The cost is expected to reduce with increased capacity utilization and completion of project.

- **Collection of user charges:**

The operation and maintenance cost is recovered by the CETP from the member industries through fixed and variable treatment charges on a monthly basis based on the actual flow by the individual member units.

6.2 Murugampalayam Common Effluent Treatment Plant

- » **About:**

The Murugampalayam Common Effluent Treatment Plant is situated near the bank of Noyyal River in the main city of Tirupur in Tamil Nadu. This CETP is registered under the Companies Act, 1956. The processing capacity of this CETP is 11 MLD to cater to the needs of 67 member-dyeing units and currently 29 member units are connected with this CETP.

- » **Collection & conveyance system:**

Three separate pipeline networks of 11 km length have been constructed between the CETP and the member units for conveyance of, a) raw effluent collection, b) recovered water, and c) brine solution.

Ductile Iron pipes with cement mortar coating have been used for raw effluent and for recovered water. HDPE pipes have been used for brine solution. Electro Magnetic Flow Metering (EMFM) system has been installed for measuring flow.

Electro Magnetic Flow Metering (EMFM) system has been installed for measuring flow. The entire system is monitored through PLC/SCADA, which is connected with the website.



Reactor Clarifier



Reverse Osmosis Plant



MVR-Evaporator



Multiple Effect Evaporator System

Fig. no. 6.4- Photographs of treatment components

» **Solid waste management:**

The solid waste management is similar to that in Rayapuram Common Effluent Treatment Plant.

» **Financing:**

Funding sources for completion of the project is presented in the table below.

Table no. 6.4: Funding pattern- Tirupur CETP

Source	Means of Funding	Original Project Cost (Rs. Crore)	Additional Project Cost (Rs. Crore)	Total Cost (Rs. Crores)	Overall %
Go/GoTN	ASIDE Grant - Gol	6.70		55.34	56%
	Special Grant – Gol/GoTN	28.70			
	Interest Free Loan-GoTN		19.94		
Industry	Promoters Contribution	10.70	9.50	20.20	20.5%
Loans	Loan from Bankers	19.90		19.90	20%
TWIC	TWIC OCD	3.50		3.50	3.5%
	TOTAL	69.50	29.44	98.94	100%

Source: Noyyal SPV, Tirupur

Approximate O&M cost per m³ of effluent (excluding sludge and waste salt disposal cost) works out to be around Rs. 218.00. Since, current utilisation capacity of the CETP is only 15% and project modification works are ongoing, the cost is expected to reduce with increased capacity utilisation and completion of project.

» **Collection of user charges:**

The operation and maintenance cost is being recovered by the CETP from the member industries through fixed and variable treatment charges on a monthly basis based on the actual flow by the individual member units.

6.3 Arulpuram Common Effluent Treatment Plant

▪ **About:**

The Arulpuram Common Effluent Treatment Plant is situated near the Tirupur - Palladam high way in the city of Tirupur in Tamil Nadu. The CETP is registered under the Companies Act, 1956. Based on the directions Judiciary and TNPCB in the year 2005, the bleaching and dyeing units in and around Arulpuram in Tirupur implemented CETPs and the ETPs at industry level to meet the Zero Liquid Discharge (ZLD) norms. The processing capacity of this CETP is 5.5 MLD and it caters to the needs of 15 dyeing units.

Seeing the success of ZLD in this CETP, other CETPs followed suit. The CETP is currently implementing project modifications including installation of an additional MEE, Ultra Filtration

(UF) and an additional stage R.O. to increase its capacity utilisation and also to reduce operating costs.

- **Collection & conveyance system:**

The collection and conveyance is similar to the Rayapuram Common Effluent Treatment Plant located in Tirupur of Tamil Nadu. Three separate pipeline networks of 3 km length have been constructed between the CETP and the member units for conveyance of, a) raw effluent collection, b) recovered water, and c) brine solution.

Ductile Iron pipes with cement mortar coating have been used for raw effluent and for recovered water. HDPE pipes have been used for brine solution.

Electro Magnetic Flow Metering (EMFM) system has been installed for measuring flow. The entire system is monitored through PLC/SCADA, which is connected with the website.

- **Treatment process:**

The treatment process consists of raw effluent collection, storage & homogenization section, biological treatment, filtration section, reverse osmosis, brine concentration treatment, thermal evaporation and salt crystallisation.

Raw effluent discharged by the member industries is collected in the collection well and pumped to the CETP. The water and brine solution recovered in the CETP are distributed back to the member units. The quantity of raw effluent, recovered water and brine solution are being quantified by the electromagnetic flow meters installed in the member units. The raw effluent received from the dyeing industries is equalised. Extended aeration type biological oxidation tanks are provided with necessary air blowers, diffusers and flow makers. The main objective is reduction of organic load (COD & BOD) and further reduction of TSS, Colour and Turbidity.

Further reduction of colour is achieved by sending the effluent through the chlorine contact system, which also increases the performance of the decolourant resin filter. The decolourant resin filter is used for removal of organics and reduction of colour. The Softener Resin Filter is used for reduction of total hardness.

Four stage RO system is designed to get overall recovery of 88% of product water by removal of dissolved inorganic salts. First and second stages are loaded with brackish water (BW) membranes, and the third and fourth stages are loaded with sea water (SW) membranes. The mechanical vapour recompression evaporator (MVR-E) increases the solids concentration from 6% to 9% w/v and helps further recovery of water. Falling film evaporator (FFE) increases the solid concentration from 9% to 22% w/v. To recover sodium sulphate from the FFE concentrate as glauber's salt adiabatic chiller is used and centrifuge (Pusher Type) is used to separate the salt and mother liquor. Forced circulation evaporator (FCE) is commissioned to concentrate and recover the water from the mother liquor. FCE concentrate is being discharged to solar pan for natural evaporation.



Colour Removal System



Quartz Filters



Brine Treatment System



Reactor Clarifier System



Sludge Dewatering System



Solar Evaporation Pan

Fig. no. 6.5- Photographs of treatment components

- **Solid waste management:**

The solid waste management is similar to that in Rayapuram Common Effluent Treatment Plant.

- **Financing:**

Funding from various sources for completion of this project is presented in the table below.

Table no. 6.5- Funding pattern- Arulpuram CETP

Source	Means of Funding	Original Project Cost (Rs. Crore)	Additional Project Cost (Rs. Crore)	Total Cost (Rs. Crores)	Overall %
Go/GoTN	ASIDE Grant - GoI	4.60		34.87	56%
	Special Subsidy- Go/GoTN	19.60			
	Interest Free Loan- GoTN.		10.67		
Industry	Promoters Contribution	7.30	3.89	11.19	18%
Loans	Loan from Bankers	13.60		13.60	22%
TWIC	TWIC OCD	2.40		2.40	4%
	TOTAL	47.50	14.56	62.06	100%

Source: Noyyal SPV, Tirupur

▪ **Operation & maintenance cost:**

The operation & maintenance cost per m³ of effluent (excluding sludge and waste salt disposal cost) is approximately Rs. 211.

▪ **Collection of user charges:**

The operation and maintenance cost is being recovered by the CETP from the member industries through fixed and variable treatment charges on a monthly basis based on the actual flow by the individual member units.

6.4 Chinnakarai Common Effluent Treatment Plant

▪ **About:**

The Chinnakarai Common Effluent Treatment Plant is situated near the Noyyal River in the city of Tirupur in Tamil Nadu. This CETP is registered under the Companies Act, 1956 and was commissioned in the year 1999 for 5 MLD. The processing capacity of this CETP is 8.0 MLD and it caters to the needs of 29 member dyeing units.

▪ **Collection & conveyance system:**

The collection and conveyance is similar to the Rayapuram Common Effluent Treatment Plant located in Tirupur of Tamil Nadu. Three separate pipeline networks of 4.5 km length have been constructed between the CETP and the member units for conveyance of, a) raw effluent collection, b) recovered water, and c) brine solution.

Ductile Iron pipes with cement mortar coating have been used for raw effluent and for recovered water. HDPE pipes have been used for brine solution.

Electro Magnetic Flow Metering (EMFM) system has been installed for measuring flow. The entire system is monitored through PLC/SCADA, which is connected with the website.



Storage and Homogenisation Tank



Biological Oxidation Tank



Secondary Clarifier



Colour Removal System

Fig. no. 6.6- Photographs of treatment components

▪ **Treatment process:**

The treatment process consists of raw effluent Collection, Storage & Homogenization section, Biological treatment, Filtration Section, Reverse Osmosis, Brine concentration treatment, Thermal evaporation and Salt crystallisation.

▪ **Solid waste management:**

The biological sludge is generated from the secondary activated sludge process which is used to reduce BOD and COD. The excess sludge from the biological oxidation tank is being discharged to the sludge thickener and dewatered through the filter press. This sludge has 75% organic and 25% inorganic content and is stored in the sludge storage yard within the CETP premises. The CETP have entered into a memorandum of agreement with a local cement plant for usage of the chemical sludge at their factory.

▪ **Financing:**

Funding sources for completion of this project is presented in table below:

Table no. 6.6: Funding pattern- Chinnakarai

Source	Means of Funding	Original Project Cost (Rs. Crore)	Additional Project Cost (Rs. Crore)	Total Cost (Rs. Crores)	Overall %
Go/GoTN	ASIDE Grant – GoI	5.60		44.42	44%
	Special Subsidy-GoI/GoTN	23.30			
	Interest Free Loan- GoTN.		15.52		
Industry	Promoters Contribution	8.40	28.72	37.12	37%
Loans	Loan from Bankers	16.20		16.20	16%
TWIC	TWIC OCD	2.90		2.90	3%
	TOTAL	56.40	44.24	100.64	100%

▪ **Operation & maintenance cost:**

Approx O&M cost per m³ of effluent (excluding sludge and waste salt disposal cost) works out to be around Rs. 283.00.

▪ **Collection of user charges:**

The operation and maintenance cost is being recovered by the CETP from the member industries through fixed and variable treatment charges on a monthly basis based on the actual flow by the individual member units.

6.5 PERTEC Common Effluent Treatment Plant

The PERTEC Common Effluent Treatment Plant is a public limited company and is located in Bakalapalli village, Vellore District, Tamil Nadu. This CETP was commissioned in the year 1995. Pernumbut is an old cluster of tannery processing industries. There are 36 tanneries presently functioning in this tannery cluster. The Bakkalapalli sector CETP serves for 19 tanneries with a capacity of 1000 m³/day, functioning with a current flow rate of about 0.5 MLD.

» **Collection & Conveyance System:**

The collection and conveyance is similar to the Rayapuram Common Effluent Treatment Plant located in Tirupur of Tamil Nadu. Three separate pipeline networks have been constructed between the CETP and the member units for conveyance of, a) raw effluent collection, b) recovered water, and c) brine solution. HDPE pipes have been used for brine solution.

Electro Magnetic Flow Metering (EMFM) system has been installed for measuring flow.

» **Treatment Process:**

In this CETP there are primary, secondary, Tertiary treatment systems with Membrane filtration technology adopted to achieve the ZLD. The CETP has taken up modification works in the pre-settler, equalization tank and also has taken up installation of new aeration system with air blowers and diffusers and softeners, ultra filtration, reverse osmosis system and thermal evaporation system etc., The work is in progress for the automation of the CETP by the PLC/ SCADA system.



Fig. no. 6.7- Treatment components of PERTEC CETP – Bakkalapalli Sector

» **Waste Management:**

The chemical and biological sludge are stored in secured land-fill and the recovered salt is stored in a storage yard within the CETP premises.

» **Operation & Maintenance Cost:**

At present, operation and maintenance cost of this CETP is Rs. 132/ kg processed.

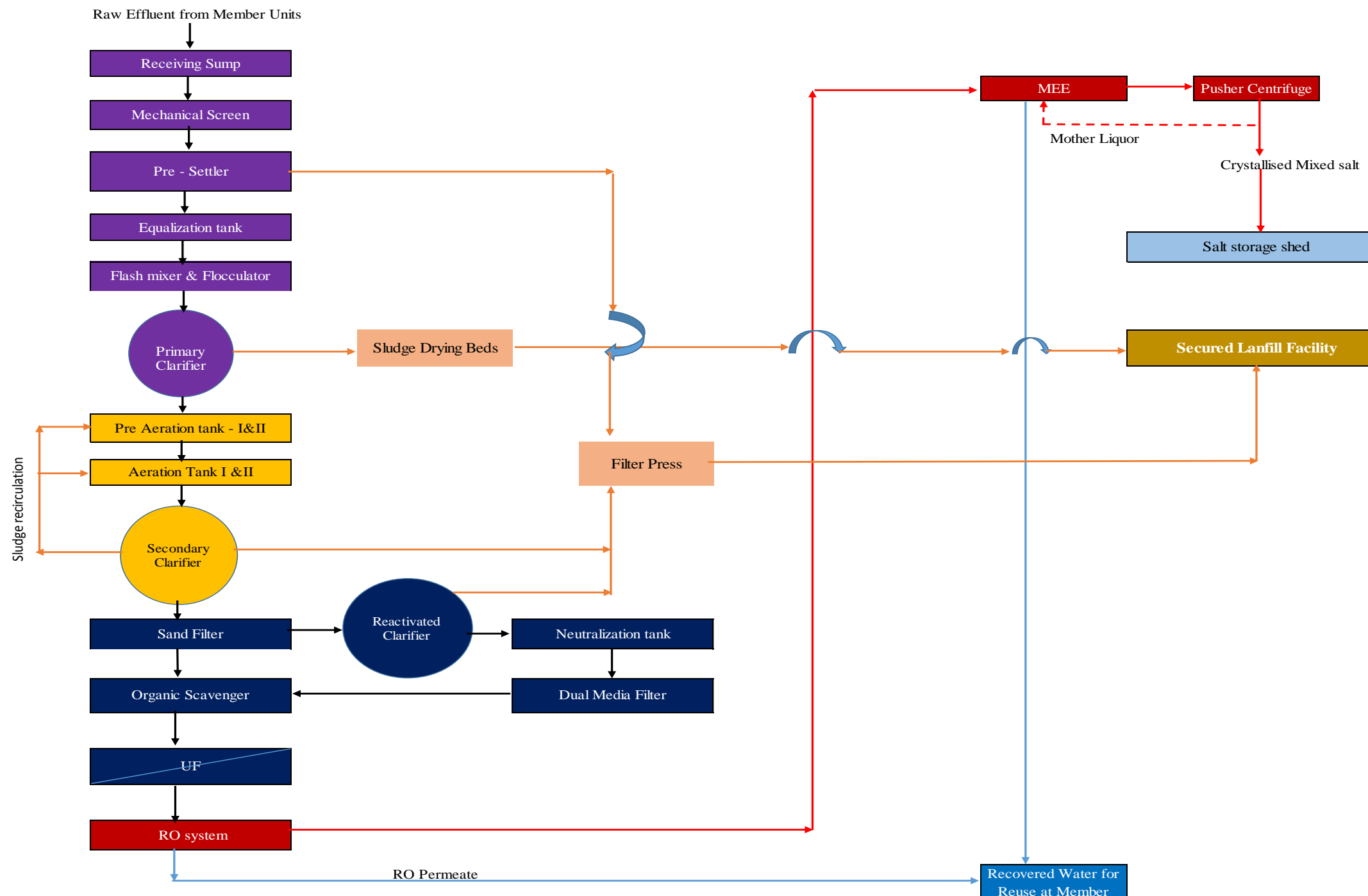

Fig. no. 6.8- Process flow diagram for Ranitec CETP

» **Waste management:**

The sludge removed from the pre settlers, the sludge generated from the primary clarifier and reactivated clarifier are dewatered in the filter press and sludge drying beds and disposed off in the Secured Landfill Facility available in the CETP.

» **Financing pattern:**

The contract value is Rs. 42 crores and the total project cost including administrative charges is Rs. 44 crores. The CETP was implemented on turnkey basis. The O&M cost for operation of the entire CETP is Rs. 250/m³. The funding pattern is as follows-

- 50 % from GOI
- 15 % from GO TN
- 35% from member units

6.6 Gujarat Eco Textile Park Pvt. Ltd.

» **About:**

Name of CETP	:	Gujarat Eco Textile Park Pvt. Ltd.
Company type	:	SPV, Private limited company.
Location / Address	:	S.No.479, 480, Vill: Baleshwar, Tal: Palsana, Surat.
Treatment capacity of CETP	:	100 MLD



Fig. no. 6.9- Gujarat eco textile park Pvt. Ltd.

Presently, 24 textile industries are catered by the CETP. The Company is registered as a private limited company. Operation and maintenance of the CETP is carried out by company itself.

» **Collection and conveyance system:**

The wastewater collection and conveyance system is through closed cement concrete drains. The treated wastewater is disposed off in a water body which finally meets Arabian Sea. The collection system is operated by the CETP.

» **Treatment process:**

The physico-chemical treatment section comprises of Lime and Ferrous Sulphate (FeSO₄) treatment section, flash mixers, flocculators, and primary settlers, while biological

treatment process is having sequencing batch reactor system. Main power source for the CETP is its own captive power plant, while DG sets are installed as a standby.

» **Collection of user charges:**

Charging system is not based on effluent quantity discharged by the member industries, but it is based on fixed number of stenters installed by the member textile industry in their manufacturing process, and corresponds to about 5 to 8 Rs per KL of wastewater. The treatment charges are collected based on monthly bills.

6.7 Globe Enviro Care Ltd.

About:

Name of CETP	:	Globe Enviro Care Ltd. (GECL)
Company Type	:	Association
Location / Address	:	Plot no. PP-1, Off Road no. 2, B/h. Kay Tex Mill, GIDC, Sachin, Surat, Gujarat
Treatment capacity of CETP	:	0.5 MLD.



Fig. no. 6.10- CETP of Globe Enviro Care Ltd.

The CETP caters to chemical industries. Presently, 50 industries are members to the CETP. The CETP company is registered as limited company. The operation and maintenance of the CETP is taken care by itself.

» **Collection and conveyance system:**

The wastewater is conveyed through road tankers and the treated wastewater is disposed in a water body, which finally meets at the Arabian Sea. The CETP on its own operates the collection system, while GIDC Sachin operates the disposal system.

» **Treatment process:**

The CETP is having equalization cum collection sump. The physico-chemical treatment section comprises of lime and FeSO₄ treatment, flash mixers, flocculators, and primary settlers as well as primary lamella. The biological treatment process is having conventional aeration system with secondary lamella and secondary clarifier. This CETP is in the process of installing advanced catalyst oxidation process and had already installed Fenton treatment process along with carbon and sand filtration system as tertiary treatment. The CETP has also applied for consent to enhance its treatment capacity to 1 MLD from the present 0.5 MLD. The condensate from MEE is proposed to be recycled.

» **Collection of user charges:**

The charging system is based on fixed monthly charges depending upon the declared load, and a variable cost based on actual load received during a particular month. The treatment charges are collected based on monthly bills. The user charges are @ about Rs 50 to 80 per KL.

6.8 New Palsana Industrial Co-Op. Society Ltd.

» **About:**

Name of CETP	:	New Palsana Industrial Co-op. Society Ltd.
Company Type	:	Co-operative Society
Location / Address	:	Block no. 301, Vill Baleshwar, Tal. Palsana Dist. Surat
Treatment capacity of CETP	:	45 MLD

The CETP caters to textile and chemical industries. Presently, 18 industries are catered to by the CETP.

» **Collection and conveyance system:**

The wastewater collection and conveyance System is through closed cement concrete drains. The treated wastewater is disposed of in a water body, which finally meets Arabian Sea through river Mindhola. The collection and disposal systems are both operated by the CETP Operator.

» **Treatment Process:**

Physico-chemical Treatment section comprises of lime & FeSO₄ treatment section, flash mixers, flocculators, and primary settlers, while biological treatment process is having conventional aeration system and secondary clarifier. Treatability study was performed present treatment setup. CETP is having Equalization cum collection sump.

» **Financing Pattern:**

The Company is registered as co-operative society. Operation and Maintenance of CETP is carried out by company itself. The capital cost for the CETP is mainly contributed from the state and central govt. subsidy and the rest is born by the member industries.

» **Collection of Charges:**

Charging system is based on fixed number of stenters installed by the member industry, and it ranges from 5 to 8 Rs. /kl. Treatment Charges is collected by generating monthly bills.

6.9 Palsana Enviro Protection Ltd.

» About:

Name of CETP	: Palsana Enviro Protection Ltd.
Company type	: Private company
Location / address	: Block No. 527-528, Opp. Nutan Petrol Pump, Mumbai – Ahmedabad Road, N.H. No. 8, Village – Umbhel, Taluka – Kamrej, Dist. Surat, Gujarat (INDIA), Pin Code – 394 325
Treatment capacity of CETP	: 100 MLD



Screen chamber
(Under



Equalization & Primary treatment
section



SBR Basin
commissioning)

Fig. no. 6.11- Palsana CETP

This CETP caters to the textile industries. Presently, 120 industries are members to the CETP. The Company is registered as private company and takes care of the operation and maintenance on its own. The capital cost for setting-up of the CETP was mainly from the grant/ subsidies of state and central government and the rest is borne by the industry members.

» Collection and conveyance system:

The wastewater conveyance is through cement concrete drains and the treated wastewater is disposed off in a water body that finally meets Arabian Sea. The collection and disposal system is operated by the CETP operator.

» Treatment process:

The existing treatment system is having conventional primary and secondary treatment facility. For primary treatment the CETP has equalization cum collection sump and screens. The physico-chemical treatment section comprises of lime & FeSO₄ treatment, flash mixers, flocculators, and primary settlers by means of clariflocculator, while biological treatment process is having conventional aeration system and secondary clarifier.

The CETP has made an up-gradation plan for which environment clearance is received for additional treatment capacity of 50 MLD. In the up-gradation plan, the effluent is proposed to be treated vide primary, secondary (SBR process) and tertiary treatment facility and the treated wastewater of 50 MLD is proposed to be recycled back to the member industries.

» Collection of user charges:

The charging system is based on fixed number of stenters installed in the textile manufacturing by the member industry which ranges from Rs 5 to 8 per KL of wastewater. The treatment charges are collected by generating monthly bills.

6.10 Pandesara Infrastructure Ltd.

» **About:**

Name of CETP	:	Pandesara Infrastructure Ltd.
Company type	:	Public Private Partnership (PPP)
Location / Address	:	At & Po. Vadod, GIDC, Pandesara.
Treatment Capacity of CETP	:	100 MLD

The CETP caters to textile and chemical industries. Presently, 129 industries are catered to by the CETP. The wastewater collection and conveyance system is through closed cement concrete drains. The treated wastewater is disposed off in a water body, which finally meets Arabian Sea. The collection and disposal system is operated by the CETP operator.

» **Treatment process:**

This CETP is having collection sumps at pumping stations and screens at inlet. Equalization tank is provided at CETP. Physico-chemical treatment section comprises of lime & FeSO₄ treatment, while biological treatment process is having sequential batch reactor (SBR).

» **Financing pattern:**

The CETP Company is registered as a limited company. The operation and maintenance of CETP is carried out by a contractor. Investment for establishment of CETP is from the subsidies of the central and state government and contribution from member industries.

6.11 Sachin Enviro Infrastructure Ltd.

» **About:**

Name of CETP	:	Sachin Enviro Infrastructure Ltd.(SIEL)
Company type	:	Not for profit company
Location / address	:	Sachin Enviro Infrastructure Ltd.(SIEL) Plot No. PP/2, Off Road No. 2, GIDC Sachin, Surat, Gujarat
Capacity of the CETP	:	50 MLD



Fig. no. 6.12- Photographs of CETP of Sachin Infra Environment Ltd.

The current capacity of the CETP is 50 MLD, however Environment Clearance has been obtained for enhancement of the treatment capacity to 80 MLD with a provision of recycling of 30 MLD treated effluent. The textile industries are the members of the CETP and the total number of industries catered is 71 Nos. The CETP has a well-established laboratory in which parameters like pH, COD, BOD, TDS, Cl, SO₄, SS, ammonical nitrogen, phenolic compounds can be analysed. For wastewater monitoring, online pH meter, online TOC meter, on-line flow meter have been installed.

» **Collection and conveyance system:**

The wastewater collection and conveyance system is through closed cement concrete drains. Treated wastewater is disposed in a water body. The wastewater collection and disposal of treated wastewater is operated by GIDC.

» **Treatment process:**

The treatment system includes primary and secondary treatment. Tertiary treatment is planned. An equalization tank is installed in the CETP and physico-chemical treatment is carried out by lime/ FeSo₄ treatment section, flash mixers, flocculators and lamella type primary settler. Biological treatment section includes single stage conventional activated sludge process. SBR is selected for proposed expansion which includes PLC/SCADA automation.

» **Waste management :**

Sludge dewatering is done by filter press and dried on sludge drying beds. Sludge thickener is planned during expansion phase of the CETP.

» **Financing pattern:**

The CETP company is registered as 'no profit no loss' company. The overall management of the CETP is looked after by a Board of Directors, under which an 'Operation Management Committee' (OMC) has been formed.

» **Collection of user charges:**

The charging system is not based on effluent quantity discharged by the member, but it is based on fixed number of stenters installed in the textile manufacturing by the member industries, and it corresponds to about Rs 5 to 8 per KL of wastewater. Payment collection mechanism is based on monthly bills.

6.12 SMS Waluj CETP Pvt. Ltd.

» **About:**

Name of CETP	:	SMS Waluj CETP Pvt. Ltd.
Name of owner	:	Waluj Industrial Association
Company type	:	Private limited company
Location / address	:	Waluj, Aurangabad, Maharashtra
Treatment capacity of CETP	:	10 MLD



Treatment Section



Primary Clarifier



Aeration Tank



ACF & PSF

Fig. no. 6.13- Photographs from Veraval CETP

The CETP caters to heterogeneous type of industries, viz. breweries, pharmaceuticals, electroplating, engineering and food processing industries. The company is registered as private limited company and operation and maintenance are done by build, own, operate and transfer (BOOT) basis. The overall management of the project is looked after by a Board of Directors. The MPCB team, CETP team and MIDC team carries out surprise visits jointly to member units for verification and checking of compliance to the norms for the effluent discharged by the CETP member units.

» **Collection and conveyance system:**

The wastewater collection and conveyance system is largely through closed drains and some industries are sending effluent through road tankers for special treatment. The treated wastewater is reused for gardening.

» **Treatment process:**

The primary treatment system consists of screening, grit chamber, and oil and grease trap and equalization tank. Physico-chemical treatment is carried out by lime/FeSO₄, flash mixer, flocculator and primary settler. Biological treatment section contains conventional activated sludge process. Polishing treatment is done by sand filtration. Carbon filtration is planned during expansion stage. Oxidation treatment with H₂O₂ is also installed. Sludge dewatering is done by filter press.

CETP has installed a special treatment plant (STP) of 0.6 MLD capacity for highly acidic/concentrated metal bearing effluent for primary treatment and metal removal.

» **Collection of user charges:**

For the industries that have special treatment needs, the treatment charges are about Rs 80 to 500 per KL., and for others the treatment charges are about Rs 17 per KL of wastewater. The quantity of wastewater is calculated based on water consumption bills of MIDC and treatment charges are charged by MIDC. Payment collection mechanism is by sending bills on monthly basis.

6.13 CETP of Patancheru Enviro-Tech Ltd. (Andhra Pradesh)

The CETP of Patancheru Enviro-Tech Ltd. has equalization tank, physico-chemical & biological treatment. Measures were taken to improve performance through process control and adding equipment for ultra-filtration through Membrane Bio-Reactor technology, which was commissioned in December 2010. The system brings down effluent COD of 3,000 mg/l and above to below 200 mg/l with corresponding BOD less than 20 mg/l and TSS about 50 mg/l or less.

6.14 CETP of Jawaharlal Nehru Pharma City at Visakhapatnam (Andhra Pradesh)

The Pharma City has been developed for specific industries like bulk drug, pharmaceuticals & fine chemicals. The CETP installed at Jawaharlal Nehru Pharma City at Visakhapatnam in Andhra Pradesh is having treatment facilities for (a) high TDS effluents, (b) low TDS effluents, (c) cyanide wastes, and (d) metal bearing sludges.

Dedicated reactors are used for treatment of cyanide and metal bearing wastes, which are transported through dedicated tankers. The high TDS effluents are transported through dedicated line and treated in a system comprising API separator (O & G), equalization tank, air stripper, clari-floculator, multiple effect evaporator & spray drier. Low TDS effluents are treated in a system of 4.5 MLD capacity, comprising API separator for O & G, equalization tank, air stripper, flash mixer, clari-floculator, high rate solids contact clarifier, sequential batch reactor and sand & carbon filters.

The COD from 4,000 to 8,000 mg/l is brought down to 400 to 550 mg/l after physico-chemical & biological treatment and subsequently to 175 to 235 mg/l after sand and carbon filters with corresponding BOD of 20 to 35 mg/l.

6.15 Online Monitoring of Treatment Plants through CC Cameras²⁰ at Tirupur

In Tirupur, the treatment plants at individual industries and CETP are monitored online through live webcasting of images from CC cameras placed at the treatment plants.



Fig. no. 6.14- Picture showing images of the CC cameras

Sl. No.	Name of the Industries	Web site	Station ID	Port	Port	Port
1	Classic Knit Processors	www.flowreadings.com/classic.aspx	107	1	2	3
2	Poppy's Art	www.poppysart.in/poppys.aspx	113	1	2	
3	Victus Dyeing	www.victusdyeings.in/victus.aspx	106, 126	1	2	
4	Allwin Textile Processing Mills	www.allwintextile.in/allwin.aspx	112	1	2	3
5	Emperor Textile Pvt. Ltd.,	www.emperorzlds.com	admin	zlds		
6	Ess Kay Yarn Dyeing	www.esskayyarn.in/esskay.aspx	118	1		
7	Mercury Process	www.mercuryprocess.in/mercury.aspx	114	1	2	
8	Wagon Wheel	www.wagonwheelzlds.com	ZLDS	wwkwzlds		
9	Arora & Tiruppur Arora	www.scottszlds.com	admin	zlds		
10	Clifton	www.nectarcrafts.in/nectar.aspx	121	1	2	

Fig. no. 6.15- Online monitoring of dyeing units in Tiruppur

²⁰ Presentation from the District Environmental Engineer, TNSPCB, Tiruppur, CETP Workshop organized by CII and GIZ at GBC Hyderabad, Nov. 23, 2012.

6.16 Combined CETP / STP Leverkusen-Bürriq, Chempark Leverkusen, Germany

» About:

The Wastewater Treatment Plant Leverkusen-Bürriq is situated at the River Rhine in the city of Leverkusen, Germany, which is one of the main chemical production sites in Europe. Since more than a century, the Chempark Leverkusen, the biggest chemical park in Germany, hosts about 40 companies from the chemical and pharmaceutical industry including Bayer AG and Lanxess AG. About 29'000 employees produce more than 5000 different chemical products, mainly inorganic and organic products, dyes, polyurethanes and rubbers as well as basic chemicals and precursors for pharmaceuticals.

Currenta, a joint venture of Bayer and Lanxess, operates the Chempark and provides with a total staff of 3400 employees the infrastructure services for the three German Chempark sites in Leverkusen, Krefeld and Dormagen including environmental services.

At the Leverkusen site, Currenta operates the Wastewater Treatment Plant Leverkusen-Bürriq treating an average of 40 MLD from the Chempark in a CETP and in a subsequent stage the effluent from the CETP with an average of 60 MLD of municipal sewage from the city of Leverkusen (up to 195 MLD including stormwater). The total capacity of the treatment plant is 264 MLD and it can treat up to 130 t/d of COD. The treatment concept is shown in the figure below.

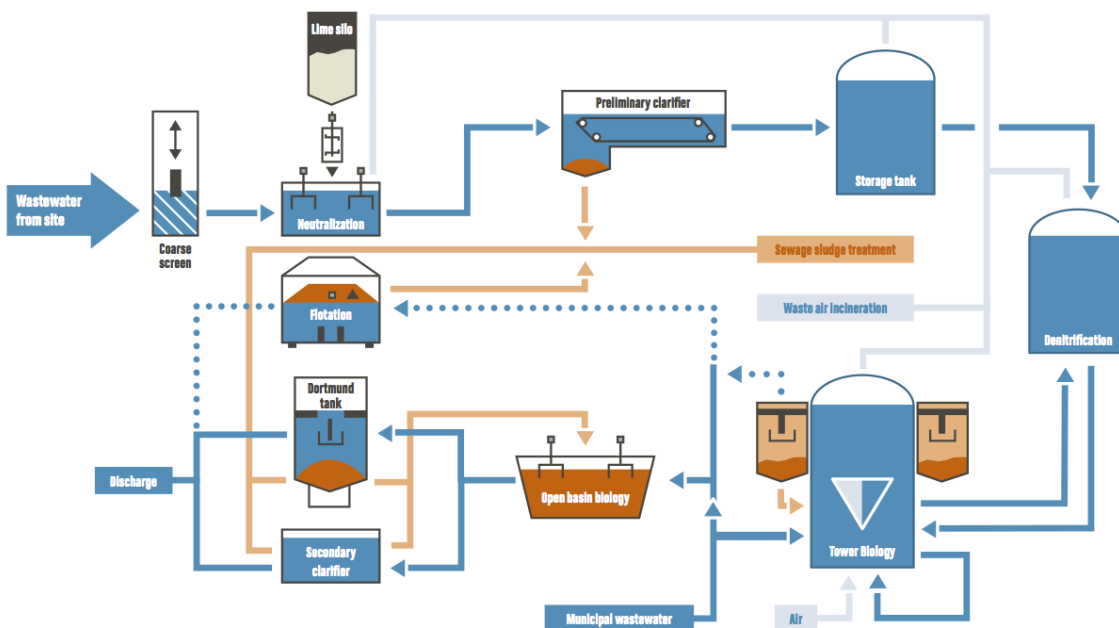

Fig. no. 6.16- Wastewater cycle in the Leverkusen-Bürriq treatment plant
(Source: Currenta)

» Process stages

The main process stages are:

- Coarse mechanical cleaning
- Neutralization
- Pre-clarification
- Intermediate storage for buffering and equalization
- 1st biological stage (Tower Biology), including nitrification/denitrification and

- phosphate precipitation
- Intermediate clarification (flotation)
- 2nd biological stage (step fed conventional activated sludge tanks) with precipitation of residual phosphates
- Secondary clarification by secondary clarifiers and “Dortmund Tanks”
- Online monitoring discharge quality control
- Sewage sludge treatment by concentration and dewatering by membrane filter presses. The filter cake is then incinerated in the sewage sludge incineration plant and the residual ash is then deposited at the landfill site.
- Exhaust air treatment by incineration

» **Removal efficiency**

The treatment plant is designed for the removal of organics, heavy metals, nitrogen and phosphorus. The COD reduction is above 90%, the outlet phosphorus concentration is below 0.6 mg/L P. The plant achieves advanced removal of nitrogen according to the demanding European discharge standards for sensitive catchment areas.

» **Tower biology**

The Tower Biology is one of the key features of the CETP and represents a solution for wastewater treatment plants based on process developments, operation feedback and many years of experience by Bayer Technology Services. Tower Biology represents a modular and flexible concept for aerobic industrial wastewater treatment. The highlights of this technology are:

- 30-50% less ground space than conventional treatment system
- All tanks are above ground.
- There are no moving parts in aeration tank and clarifier.
- The towers are made of polypropylene that has high resistance against corrosion and erosion. It gives long operational time without maintenance.
- Aeration is @ 3.2 to 3.8 kg O₂/KWh over long operational time.



Fig. no. 6.17- View of tower biology system at Chempark Leverkusen

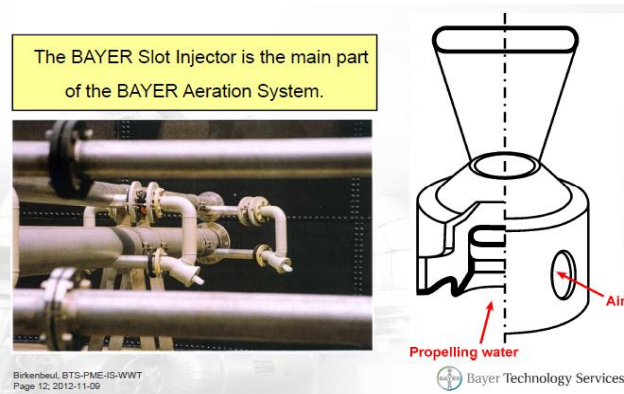
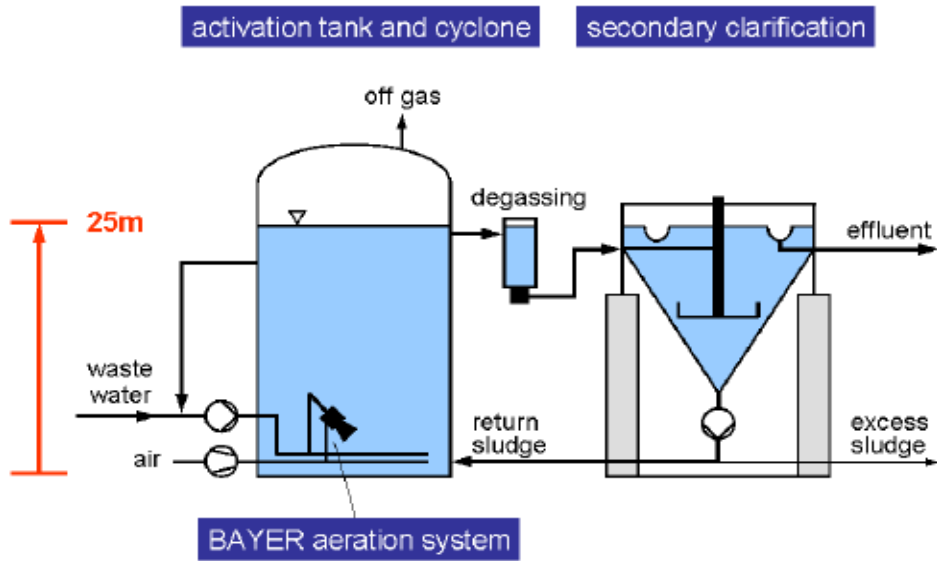

Fig. no. 6.18- Schematic diagram of tower biology and injector system

References:

http://www.currenta.com/tl_files/currenta/medien/currenta/downloads/pdf/CUR_Klaeranla ge_en.pdf

http://www.currenta.com/tl_files/currenta/medien/currenta/downloads/pdf/CUR_Klaeranla ge_A5_en.pdf

Additional information available at:

<http://www.currenta.com/environmental-services-1202.html>

6.17 CETP Basel Chemical Industry, ProRheno AG, Basel, Switzerland

» About:

The CETP Basel Chemical Industry is situated at the River Rhine in the city of Basel, Switzerland, which is the main production sites for the Swiss chemical and pharmaceutical industry. Since 1982, the ProRheno AG, a joint service providing company of the different stakeholders, provides the services for the treatment of wastewater from households, commercial buildings and industry in the Basel region. The two cantons of Basel-Land and Basel-Stadt together own 51 percent of the share capital of ProRheno AG. The company Huntsman Advanced Materials (Switzerland) GmbH, F. Hoffmann-LaRoche Ltd, Novartis Pharma AG, BASF AG Switzerland and Syngenta Crop Protection AG jointly 49 percent.

The ProRheno AG consists of the STP Basel (municipal wastewater), the CETP Basel Chemical Industry (cleaning of chemical waste water) as well as the sludge treatment (incineration of the resulting sludge) and common facilities for the operation of the sites (laboratories, workshops, etc.). The site covers an area of 76.3 hectares. The CETP treats an average of 4.4 MLD from the chemical/pharmaceutical industry while the STP Basel treats 93 MLD on average.

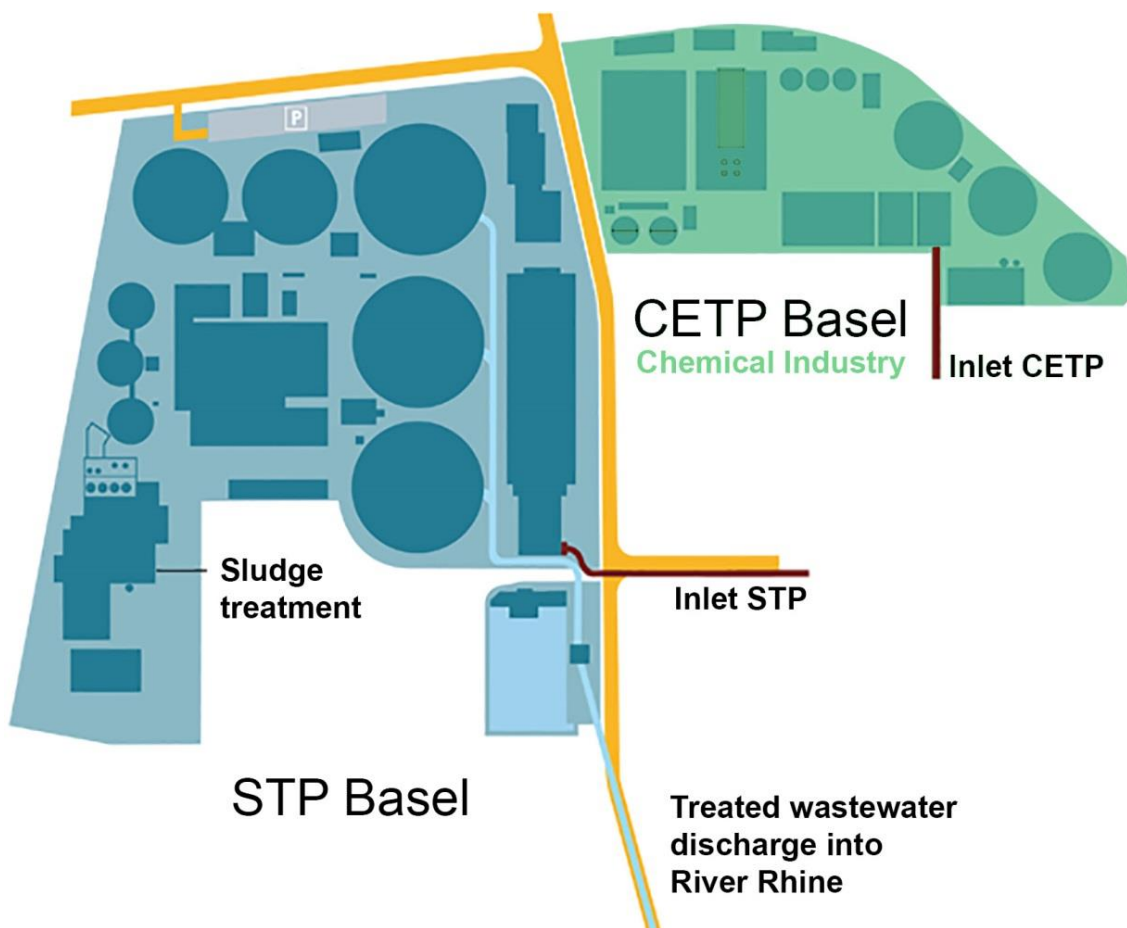

Fig. no. 6.19- Wastewater treatment plants in Basel
(Source: ProRheno AG)

» Process stages

The main process stages of the CETP Basel are:

- Mixing of the different effluent streams
- Neutralization
- Pre-clarification
- Storage for buffering and equalization
- Physico-chemical treatment (flocculation/coagulation)
- Biological treatment (conventional activated sludge with volume aeration) phosphate removal
- Degassifiers
- Final clarification
- Final flocculation and flotation
- Online monitoring discharge quality control
- Sewage sludge treatment by settling and dewatering by centrifuges. The filter cake is then incinerated in the sewage sludge incineration plant and the residual ash is then deposited at a sanitary landfill.
- Exhaust air treatment collected from all tanks and units by GAC adsorbers

» **Removal efficiency**

The CETP achieves an average reduction of COD of 92.4 % (2012), reaching an effluent COD of 157 mg/L and an average BOD reduction of 99.1 % reaching an effluent BOD₅ concentration of 11 mg/L. The TSS at the outlet are 13 mg/L. Total Phosphorus is below 0.1 mg/L, the outlet phosphorus concentration is below 0.6 mg/L P. One key parameter for the quality control is adsorbable organic halogen AOX. The average concentration at the outlet was 0.042 mg/L against the discharge standard of 0.08 mg/L AOX.

» **CETP Basel / STP Basel: Costs of wastewater treatment incl. sludge treatment (* 1 CHF (Swiss Franc) = 1.1 US\$)**

	CETP Chemical Ind. 4.4 MLD			Municipal STP 93 MLD		
	2010	2011	2012	2010	2011	2012
Costs per year in million CHF*	4.71	4.58	4.66	5.33	5.52	5.46
CHF/kl wastewater	4.84	4.77	5.69	0.23	0.26	0.24
CHF/kg DOC reduced	6.71	6.81	8.17	2.04	1.73	2.02

» **On-going upgradation**

The CETP and STP Basel are currently under up-gradation for advanced nitrogen removal and removal of organic micro pollutants. Nitrogen removal will be achieved biologically by nitrification and denitrification while activated carbon adsorption shall provide the removal of trace organic compounds.

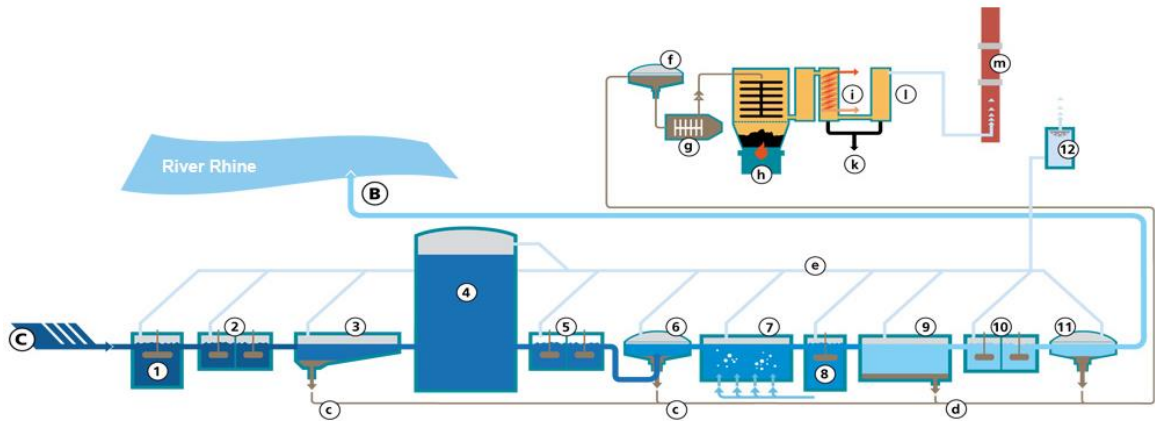

**Fig. no. 6.20- Treatment train, aerial view and GAC adsorption for air pollution control at the CETP Basel
(Source: ProRheno AG)**

References:
<http://www.prorheno.ch/>

6.18 Common Effluent Treatment Plant, Vapi: Approach for Retrofitting/Modernisation

The Gujarat Industrial Development Corporation (GIDC) Industrial Estate at Vapi (Gujarat) has several chemicals, dyes, paper and other industries that produce significant quantities of wastewater including not readily biodegradable and toxic effluents. The industrial estate has a Common Effluent Treatment Plant (CETP), which has problems of compliance with the prescribed standards, sludge handling issues, requirements for additions of treatment units as well as need for improved operation and management. Also, the industrial estate at Vapi is ranked as critically polluted by the environmental authorities due to wastewater issues and other environmental problems, and the performance improvement of CETP is a priority.

The inflow to the CETP is contributed by about 545 industries mainly from textiles, inorganic chemicals and pesticides, paper, and pharmaceuticals sectors. The volume of flow is about 55 MLD. The main treatment units of the CETP are screens, grit chambers, equalisation tanks, flocculators, primary clarifier, aeration tanks, secondary clarifiers, filter press for secondary clarifier sludge, sludge thickener and centrifuge decanter for primary clarifier sludge. The treated wastewater is discharged to the Damanganga River, which joins the sea, a few kilometres downstream. The CETP, for about 10 MLD, has a UASB followed by a clarifier and degassifier.

The approach followed for planning up-gradation/modernisation of the VAP CETP is summarised below:

- » Problem analysis
- » Identification of alternatives/concepts for wastewater treatment
- » Lab testing of preferred solutions
- » Comparison of alternatives for treatment of wastewater and arriving at preferred concept
- » Pilot tests of the preferred concept – undertaking of pilot tests to ascertain the viability of the identified technical solutions
- » Pre-basic design of the CETP based on the identified solutions



Fig. no. 6.21- Impression of the aeration tanks and the secondary clarifiers (March 2014)

Problem analysis:

For problem analysis, performance assessment of the CETP was undertaken. The key parameters reviewed were for COD, BOD₅, NH₄-N, and SS as well as the volumetric flows. Problems associated with aeration in biological treatment, weirs in clarifiers, CAACO treatment, FACCO treatment etc. and efficiency of various treatment units were identified. Also, problems related to inflows and operation and management were identified.

The problems were related to structural damages, insufficient oxygen and its absorption, problems of choking, inhibition to bacterial growth due to toxicity, sludge with high moisture content and chlorides/heavy metals/toxic organics etc.

In addition to repairs and maintenance solutions, the treatment options identified included:

- » **Two stage treatment - Anaerobic treatment (UASB) followed by aerobic treatment:** Besides a conventional activated sludge process consisting of an aeration tank and clarifier, the aerobic treatment could be through a compact sequencing batch reactor (SBR) or an attached growth system such as a moving bed bioreactor (MBBR).
- » **Two stage aerobic treatment - High rate followed by low rate treatment:** The 1st stage could be either built as a conventional activated sludge tank with surface aerators or coarse bubble aerators or – in a more compact form – as tower biology. The 2nd stage is typically a conventional activated sludge system with volume aeration or surface aeration, which also provides treatment of nutrients such as nitrogen and phosphorus.
- » **Post-treatment for removal of refractory organic compounds: Advanced oxidation process followed by bio-filtration:** In lab tests, it turned out that a relatively high percentage of the influent COD is hardly biodegradable under “standard” conditions, and hence additional measures are required to address this refractory COD consisting of a wide range of organic compounds from mainly chemical, pharmaceutical, textile and pulp & paper industries. It is anticipated that by oxidative post-treatment using ozone or ozone/H₂O₂ a high percentage of these compounds could be partly oxidised and become better biodegradable. With improved biodegradability a biological post-treatment such as aerobic bio filtration or fluidized bed reactor could reduce the COD to the level required. It was assumed that such an post-treatment should primarily serve as temporary solution till the main biological stages provide the full treatment and measures at the industry (source) level will reduce the influent load further.
- » **Lab tests/pilot tests:**

The overview of the suggested lab tests and pilot tests is given below.

Table no. 6.7- Overview of conducted tests

	Activity	Study scale
1	Biodegradability Zahn-Wellens Test	Lab scale
2	Two stage treatment aerobic activated sludge after primary treatment	Pilot scale

3	MBBR treatment aerobic activated sludge after primary treatment	Bench scale
4	Bioaugmentation <i>using lab culture</i> using soil culture from final outlet	Pilot scale Lab scale
5	Chemical Oxidation (O_3 and H_2O_2)	Lab scale + Pilot scale
6	UASB followed by ASP	Lab scale
7	Anaerobic Digester	Pilot scale

Main observation from the lab and pilot tests:

- » Biodegradability tests revealed a very variable degradability between 60 to 80% of the COD.
- » Several methods for improved biological removal were studied: two-stage treatment, MBBR, bio augmentation, and anaerobic treatment.
- » Pilot tests also studied optimised trains, such as
 - Two stage aerobic treatment (AE - AE)
 - UASB – aerobic treatment (AN - AE)
 - COD removal was limited due to refractory compounds reaching only about 400 mg/L filtered COD in the outlet.
 None of the tested technologies achieved the targeted COD and SS concentrations.
- » Nitrification occurred at higher aeration rates reducing the NH_3-N concentration to below 20 mg/L.
- » Advanced treatment methods have to be applied to remove the refractory organic compounds.
- » Chemical oxidation methods (ozone or ozone/peroxide) appear to be promising.
- » Ozonation tests have not yet been applied with the required high O_3 concentrations and subsequent biological treatment. Additional pilot tests should operate on a continuous mode.

Improved aeration and biological treatment can provide nitrification and reduce the NH_3-N concentration below 20 mg/L. Ozonation of secondary effluent was able to reduce the refractory COD from the secondary effluent by up to 20% if high O_3 dosages were applied. Further reduction of the COD can be achieved through subsequent biodegradation of the ozonated water. The results from the tested samples using low ozone dosages were not satisfactory. Combinations of ozone and peroxide were able to improve the biodegradability of the primary overflow and are expected to have a similar effect on the secondary overflow. Extension concept

The TDS concentration cannot be reduced economically within the main treatment of the CETP since this would require expensive desalination technologies such as thermal evaporation or reverse osmosis or combinations thereof. The effluent salinity should however be controlled at their source within the industries or through desalination of concentrated streams either onsite at the CETP prior to mixing with the main raw water stream.

For biological treatment, the pilot tests studied several biological treatment processes and approaches to upgrade the existing units. The biological treatment could be upgraded for example by a two-stage treatment, implementation of MBBR treatment.

While MBBR appears to be a feasible and sound improvement of the CAS treatment, SBR might lead to a slight performance loss in terms of COD removal but could increase the removal of nitrogen by nitrification and denitrification. SBR also has the advantage of a low footprint. The preferred biological method to be implemented has to be derived from a cost comparison using the test results from the pilot tests for the dimensioning of the respective units

Table no. 6.8- Overview of discussed treatment alternatives for improved / modified biological treatment

Process	Main features	Advantage	Disadvantage	Comment
Moving Bed Bioreactor (MBBR)	<ul style="list-style-type: none"> Attached growth Different carrier materials 	<ul style="list-style-type: none"> High SRT Enrichment of specialized bacteria Reduced excess sludge 	<ul style="list-style-type: none"> Requires volume aerators, e.g. fine bubble aerators 	Pilot tests ongoing
Sequencing batch reactor (SBR)	<ul style="list-style-type: none"> Activated sludge process in batch mode Minimum two parallel tanks Cycling of different treatment steps in parallel tanks (fill, aerate, settle, decant, idle) No separate clarifiers 	<ul style="list-style-type: none"> Low footprint Nitrification and denitrification can be easily included Well controlled process Less piping and equipment 	<ul style="list-style-type: none"> Requires volume aerators, e.g. fine bubble aerators Complex movable parts, e.g. decanter Corrosion risk of movable parts Applicability to poorly biodegradable wastewater questionable (reduced contact time) 	Successful application in India in several domestic and industrial treatment plants
Soil-Bio filtration	<ul style="list-style-type: none"> Treatment of effluent during soil passage 	<ul style="list-style-type: none"> Natural treatment process Low energy demand Enrichment of specialised bacteria possible 	<ul style="list-style-type: none"> Risk of clogging Risk of overloading Risk of incomplete removal Risk of large waste volumes in case of failure 	No proven demonstration or full-scale application in industrial wastewater

Advanced wastewater treatment

The lab and pilot test results clearly show that all improvement of the biological treatment is limited by the poor biodegradability of the organic compounds discharged by the industries. Currently about 150 mg/L dissolved COD require additional treatment. Table no. 6.7 shows the main characteristics of applicable processes. Figure 6.7 presents the potential implementation of chemical oxidation or activated carbon filtration after the secondary clarification.

Table no. 6.9- Overview of advanced wastewater treatment methods

Process	Main features	Advantage	Disadvantage	Comment
Oxidative processes	<ul style="list-style-type: none"> • Oxidation of refractory compounds • Potential agents: O₃, H₂O₂, Fenton, combinations thereof 	<ul style="list-style-type: none"> • Improved bio-degradability • Rapid reduction of colour • No additional waste 	<ul style="list-style-type: none"> • Post-treatment required • Increased energy demand • pH dependent • Inlet with low SS and NH₄ required 	Tests ongoing
Adsorptive processes	<ul style="list-style-type: none"> • Adsorption of organics and heavy metals onto activated carbon • Granular or powdered form (GAC vs. PAC) 	<ul style="list-style-type: none"> • Highly efficient for a broad range of compounds • Regeneration of GAC possible 	<ul style="list-style-type: none"> • Waste production • Risk of clogging if influent is not low in SS • Might require pre-treatment (e.g. DMF) 	No tests yet conducted
Membrane processes	<ul style="list-style-type: none"> • Retention of all suspended and soluble compounds depending on pore size /MWCO • Pressure up to 50 bar • Salinity removal and small size organics by Reverse Osmosis 	<ul style="list-style-type: none"> • (Almost) complete removal of organics • High reduction of salinity • Modular design 	<ul style="list-style-type: none"> • High costs • Treatment of concentrate • Fouling risk • Scaling risk • Pre-treatment requirement • Chemical requirement • Challenging operation 	Applied in ZLD concepts

Typically there is a hierarchy of measures determined by the involved costs. Wherever possible chemical oxidation such as ozonation or ozone + peroxide provide economic treatment of refractory compounds by rendering them biodegradable. These treatment methods also avoid the production of additional waste and can use oxygen, which are produced onsite. To utilize the improved biodegradability biological post-treatment by MBBR or similar processes should be provided. After the MBBR the remaining SS have to be removed to comply with the required effluent standards.

As alternative to chemical oxidation, however often at higher expenses, activated carbon can be used to adsorb the refractory COD. Granular activated carbon (GAC) tests have not yet been conducted. Thus a sound evaluation of this method is not possible. To avoid clogging, fouling and frequent backwashing of the GAC filters, the secondary effluent should be prefiltered by dual media filtration. Since the remaining COD is rather high, frequent regeneration of the GAC will be required, either onsite or by the supply.

As short-term measure activated carbon could be also added in powdered form (PAC) to the activated sludge tank. This so called PACT process (= powdered activated carbon treatment) combining activated sludge and PAC is used in several industrial wastewater treatment plants. In this case the waste production would increase by the amount of added PAC. However, dewaterability and caloric value of the sludge would increase as well.

It is recommended to conduct a comparison of the alternatives proposed in figure below to identify the optimum short- and long-term solution.

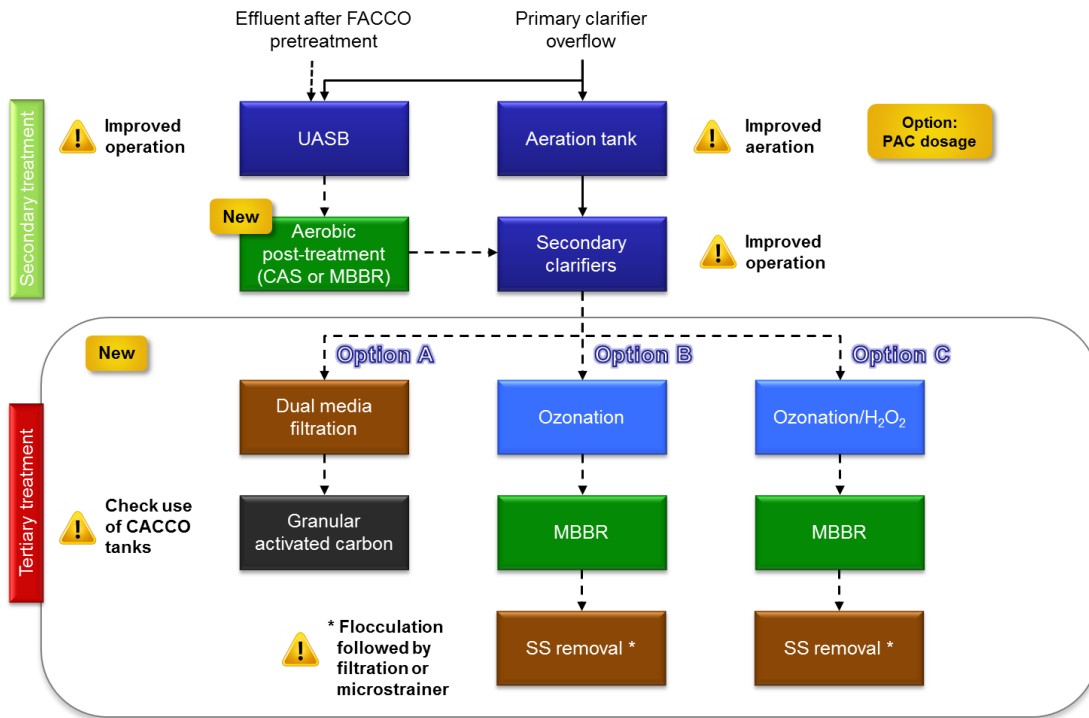

(UASB = upflow anaerobic sludge blanket, PAC = powdered activated carbon, CAS = conventional activated sludge, MBBR = moving bed bioreactor, SS = suspended solids)

Fig. no. 6.22- Potential advanced treatment options to address refractory COD and supportive measures

Suspended solids removal

To reduce the addition of flocculants and polyelectrolytes currently applied in high concentrations at several points of the CETP, it is recommended to add a suspended solids removal step. The preferred technology has to be selected based on the size of the particles and their other main characteristics. Several methods for SS removal are available, e.g.,

- » Dissolved air flotation (DAF)
- » Microstrainers
- » Dual media filtration (DMF)
- » Membrane filtration (MF = microfiltration)

DAF is widely applied in treatment of industrial effluents and allows increase of SS removal by chemical additives. DMF is already a standard technology in CETPs in India while

microfiltration still has not been applied in Indian CETPs. MF will result in much higher cost and is only recommended if other methods fail.

The proposed methods should be tested on site and cost comparison should be conducted based on the test results.

6.19 MANA Common Effluent Treatment Plant, Mallapur & Nacharam

The Industrial Parks at Mallapur and Nacharam are situated in the Hyderabad covering an area of 360 acres with more than 650 industries. The industrial units are small scale, heterogeneous in nature and mainly comprises of engineering, chemicals, pharmaceuticals, wood, papers, metals and polymers. The project got an Environmental Clearance from SEIAA. The CETP consists of preliminary, primary, secondary and tertiary treatment. The following figure shows flow chart of the treatment plant.

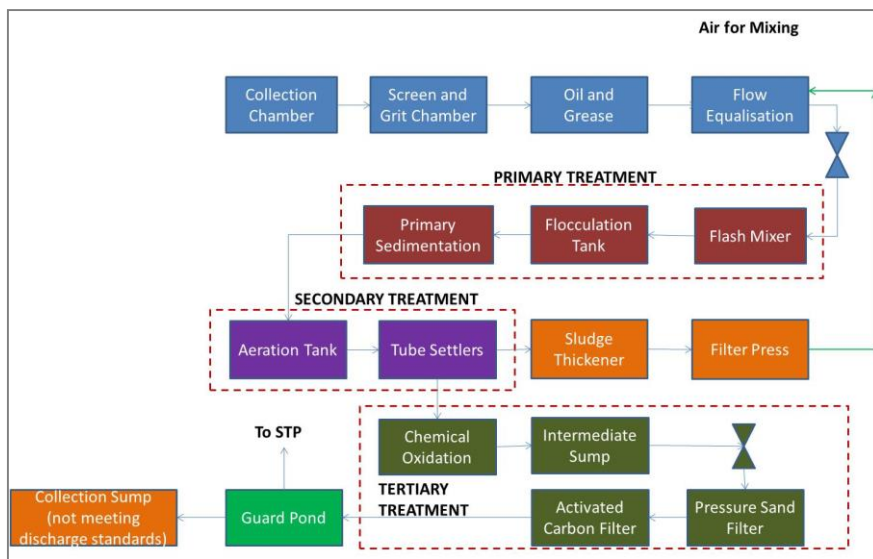

For managing the CETP, SPV by the name of Mana Effluent Treatment Plant Ltd (Mallapur & Nacharam) was registered as a company under the Companies Act of 1956. The SPV has a Board Directors from both Mallapur and Nacharam industrial areas. The role of SPV is to make sure the CETP runs smoothly and the member industries pay the user charges on time. The stakeholders raised the equity share capital of Rs. 200 lakhs.

The Andhra Pradesh Industrial Infrastructure corporation ltd (APIIC) played an important role in successful establishment of the CETP. APIIC allotted 3.76 Acres of land for the phased construction of CETP with an ultimate capacity of CETP of 8 MLD. The sewerage system in the industrial parks was constructed by APIIC. On behalf of the State Government, contribution of 25% of the CETP costs made as a subsidy by APIIC. Further, APIIC gave a soft loan to the industrial area local authorities in Mallapur and Nacharam for construction of sewerage line from CETP outlet to the Sewage Treatment Plant, as was required from regulators.

A private operator has been contracted for the CETP on build own, operate, transfer basis.

The CTEP was initially planned to be developed on BOOT basis by the private operator. However, due to complexities involved with laying of conveyance systems, industries unwilling to connect effluents to CETP etc. the CETP progress was very slow. However, subsequent to the formation of SPV and APIIC playing proactive role, the CETP got completed.

6.20 Green Procurement Procedure: New CETP at APSEZ

For procurement of CETP services for the Andhra Pradesh Special Economic Zone (APSEZ), Visakhapatnam (AP), EUs “Green Public Procurement Criteria for Waste Water Infrastructure” are being used for setting pre-qualification criteria for selection of potential CETP operators.

The pre-qualification criteria (PQ) for short-listing interested bidders, incorporated some of these criteria. For example, this includes:

- » **Ability of the bidder:** The consultants (engineers, planners and architects) shall demonstrate that suitably qualified and experienced personnel will undertake the works/services. The consultant should describe the composition and qualifications of the team that is to undertake the services.

Qualifications and abilities of the consultants can include experience and technical capacities as regards one or more of the following fields/areas:

- Planning and design of waste water infrastructure (specific items within sewer systems, waste water treatment and sludge treatment should be specified)
- Incorporation of energy-efficient process equipment
- Environmental impact assessment and environmental management including incorporation of measures to:
 - Reduce the total environmental impacts from discharge of waste water into the receiving water bodies;
 - Perform a Life Cycle Assessment (LCA) and prioritisation of environmental impacts; and
 - Set up and calculate Life Cycle Cost (LCC).

Verification: The bidder shall supply a list of comparable projects recently carried out (number and time frame of projects to be specified by the contracting authority), certificates of satisfactory execution and information on the qualifications and experience of staff. Where relevant, bidders may also submit a copy of their environmental management system, whether third-party certified (e.g. EMAS, ISO 14 001) or in-house to attest to their technical capacity.

- » **Technical evaluation criteria**

Approach: The consultant should describe how he intends to implement the project overall in order to achieve the project objectives, especially the Consultant's environmental understanding of the project, such as understanding of the environmental legal framework, local environmental conditions, environmental impact assessment, etc.

Methodology: The consultant should describe the specific methods to:

- » Estimate the financial LCC of the alternatives
- » Assess the environmental impacts using an LCA approach

The consultant should submit a broad approach and methodology (2-3 pages) for setting-up CETP at APSEZ

Organisation and team: The consultant should describe the organisation, qualification and experience of the team that is to undertake the services.

- » Technical – 50%
 - Approach and Methodology including Timelines – 10 %
 - Organisation and Team Composition – 25 %
 - Environmental Criteria – 15%

- » Financial – 50%
 - Company Net Worth – 20%
 - Capital cost (Installed) – 10%
 - O& M Cost - 10%
 - Energy Efficient Technologies / Environmental Cost – 10%

Verification: The tenderer's proposals must clearly set out their understanding of the project, the proposed methodology and the project management and organisation.

7 Policy Interventions Required for CETPs

7.1 Summary of Key Concerns with CETPs

- **Design/technology related issues**

- » **Feasibility studies:** The quantities of and quality of wastewaters, availability of treatment systems at the industry level, options for conveyance systems, disposal options including recycle/reuse etc. are not adequately studied. Non-availability of data and non-disclosure of data during surveys by the industries is a major problem. Many a times, CETPs are over designed for much more than the effluent generated.

- » **Choice of technology:** Availability of technological options and their financial viability is not often adequately evaluated before zeroing on the applicable technologies. Treatability aspects, particularly related to toxicity, heavy metals, refractory COD, high TDS, Ammoniacal Nitrogen etc. needs attention.

The aspects of difficulties in operation and maintenance, lack of trained man power and external factors such as failures of electricity supply are not taken into consideration.

The recycle and reuse concepts are not integrated. The aspects of energy efficiency are also not considered.

- » **Standard approach not followed:** It is important to design the CETPs taking into consideration the treatability of effluents and all the complexities involved due to wastewaters being collected from several individual industries. Lab testing and pilot testing procedures are not undertaken before initiating designing of the CETPs. Proper approach should be followed for planning and designing of new CETPs or modernisation or expansion of the existing CETPs.

- » **Inadequate planning:** Due importance is not given for the planning of CETPs, due to which various issues arise at a later stage.

Also, there is a time lag between conceptualization of a CETP and its actual operation date. During this time, the type of industries envisaged in the design stage may change and an entire new set of industries may emerge. Thus there will be a mismatch between actual effluent quality and the designed system to treat it causing non-conformity in the outlet treated parameters.

In the case of new industrial estates, provisions are not adequately made even if CETP requirements are foreseen. The types of industries to be allowed or not to be allowed, the conveyance systems, land requirements for CETP etc. are not well defined and adhered to later on while allotting lots to industries.

- » **Lack of guidelines:** There are no guidelines or reference documents available for planning, designing and management of CETPs in the country.

- » **Lack of standards for CETP construction:** There are no specific set of standards for construction of CETPs. An important factor in decision-making is the expected service life of the assets to be built or already operating. The construction standards will help chose the right kind of materials, address corrosion risks, take into consideration resource efficiency and energy efficiency etc.

- **Flow/conveyance related issues**

- » **Heterogeneity and flow variation:** Variation in effluent quantity and quality within the same day as well as from day to day has critical impact on the performance of the CETPs. Lack of adequate equalization leads to fluctuations in quantities and quality of effluent in various treatment units of CETP, due to which the treatment units may not perform as desired.

Whether all types of effluents are mixed or are segregated and conveyed plays an important role in treatment. Particularly, the wastewaters with heavy metals, toxicity, high COD and high TDS are a concern for treatment in CETP.

- » **Improper wastewater conveyance systems:** Lack of separate conveyance systems for different types of wastewater, for example for domestic sewage and for industrial wastewater or for streams with very high refractory COD, poses problems in the CETP. Also, the type of material used for the pipelines used for conveyance of wastewater is an issue as some materials are not suitable to acidic or corrosive or toxic effluents.
- » **Wastewater flows not regulated:** The uncontrolled discharge of wastewater from the individual industry premises to the CETP is a major problem to treatment of wastewater in CETPs.
Many CETPs have problem of overloading due to increased volumes of wastewater over time and the designed treatment systems not being able to take the increased load.
- » **Impacts from improper disposal of treated effluent:** Quite often there is no proper place of disposal for treated wastewaters. The receiving water bodies often lack flows and adequate dilution for absorbing the pollution loads from the treated wastewaters. The treated wastewaters have potential to environmental impacts, depending on the flow and uses of the water in the receiving water bodies.
- » **Lack of monitoring:** Quite often, CETPs do not have proper monitoring facilities at the inlet and outlet, both for quality and quantity.

- **Sludge disposal issues**

- » The waste generated by CETPs is categorised as hazardous waste and needs to be disposed safely in accordance with the applicable laws. Safe disposal of these wastes is often a major problem.
- » There is an acute problem of sludge storage and disposal in most of the CETPs due to non-availability of suitable land and hazardous waste disposal facility in the proximity.

- **Issues with Zero Liquid Discharge**

- » **Waste salt disposal:** ZLD results in generation of hazardous solid wastes particularly waste salts that cause disposal challenges. Due to scarcity of land and where TSDF facility is not available at reasonable distances, the problems are even severe.
- » **High cost of operation:** The high cost of operation of a ZLD is a major challenge. The typical O&M cost of a ZLD plant ranges between Rs. 200- 250 per KL of wastewater treated. The recovery of water offsets the cost by Rs. 50 to Rs. 70 per

KL, while recovery of Sodium Sulphate salt (in the case of some Textile dyeing CETPs) reduces the cost by Rs. 30 to 40 per KL.

- » **High power consumption:** Carbon footprint of a ZLD facility is another major concern. The typical power consumption ranges from 8 to 10 kW/m³. The thermal evaporators alone consume about 20 – 40 Kw/m³, in addition to several tons of firewood used for the boilers.
- » **Non-uniform application across the country:** Non-uniform application of ZLD standards across the country for similar industries has serious impact on the competitiveness of the industries in certain states, e.g. while industries in Tamil Nadu are forced to implement ZLD, industries elsewhere in the country are permitted to discharge into rivers and sea.

- **Issues related manpower/capacities**

The country does not have a system of certified operators and managers that can handle the operations and management of a CETP. This poses heavy risks on the CETPs, even on those that are very well designed and advanced technologies are installed.

- **Issues related to business models**

Quite often it is observed that what is most appropriate business model has been not been analysed well before setting up of a CETP. There are no guidelines on viable business models for setting up of CETPs.

Procurement procedures are not well laid out for procurement of CETP services. No healthy and competitive market has been developed for the CETP operators where valued and reliable services can be appreciated.

There is a need for an enabling business environment for the financial institutions to fund CETP infrastructure projects in the country.

- **Management related issues**

CETP struggles to recover the operating & management costs, including interest on capital costs invested, costs towards chemicals, electricity, manpower etc. Industries many a times complain that the rates for user charges are not rationally fixed and requires revision from time to time, as may be necessary, in a transparent manner.

Roles of multi-stakeholders are associated in running CETPs. However, the management models are not well defined. For example, if the member/user industry of CETP is on the board of directors of the CETP, there would be issues of conflict of interest.

7.2 Suggestive Policy Measures

- **Objective of the proposed policy measures**

“To ensure sustainability of the Common Effluent Treatment Plants (CETPs) in the country by adopting economically and environmentally viable solutions so that environmental compliance is enhanced”.

- **Focus areas of policy measures**

The policy measures are required catering to the following areas:

1. Grant subsidy for promotion of CETPs
2. Promotion of recycle and reuse of treated wastewater
3. Facilitation of development of skilled manpower for operation and management of CETPs
4. Market development for CETPs
5. Support for energy efficiency in CETPs
6. Promotion of Zero Liquid Discharge
7. Promotion of R & D related to CETPs

Details are given below.

▪ **Grant subsidy for promotion of CETPs**

The existing CETP scheme of the MoEF should be made applicable subject to the following:

- a) Submission of a detailed project report along with findings/results based on a standard approach following the important steps as below in identifying the solutions and arriving at basic design of the CETP:
 - » Problem analysis
 - » Identification of alternatives/concepts for wastewater treatment
 - » Proofing of principles – this is required to verify that the identified concepts/solutions would work. This is done through lab testing of the solutions.
 - » Parameter studies – systematic studies are required to vary a number of model parameters to arrive at optimisation of process conditions for treatment of wastewater.
 - » Assessment of energy, materials and resource consumption
 - » Comparison of alternatives for treatment of wastewater and arriving at preferred concept
 - » Pilot tests – undertaking of pilot tests to ascertain the viability of the identified technical solutions
 - » Pre-basic design of the CETP based on the identified solutions
- b) Formation of a SPV (special purpose vehicle) is a must for the purpose of a CETP.

A Special Purpose Vehicle (SPV) must be set up for each CETP by the public bodies such as the state industrial development corporations or state industrial infrastructure development corporations or private agencies. The overseeing of the planning, development and management of the CETP shall be responsibility of the SPV.

The board of SPV should be free from the influence of the industry members thus minimizing hindrance to the day to day functioning of the CETPs. SPV should have the powers to accept or not accept industry effluents from a specific industry in case the unit is not complying with the discharge norms.

The existing central/state assistance as per MoEF CETP scheme is as below, which should continue:

Central assistance (subsidy) of 50% of the total project cost subject to a ceiling of Rs. 20 crore without ZLD and Rs. 40 crore for projects with provision of ZLD.

The Central assistance shall also be restricted to Rs. 1.5 crore per MLD for a CETP project without ZLD.
The State share shall be 25% of the total project cost.
The project proponent's contribution shall be 25% out of which at least 15% shall be the contribution of the project proponent and the balance could be raised by the concerned project proponent from loan from Banks/Financial institutions

Additionally, **service tax exemptions** should be allowed for a period of at least 5 years during the operational phase of the CETP.

▪ **Promotion of recycle and reuse of treated wastewater**

Water is an important resource. To encourage recycle and reuse of treated wastewater that complies with the required standards for the use it is intended (e.g., agricultural use, industrial use), the central assistance from MoEF should include the following:

Tertiary treatment systems	Central assistance (subsidy) of upto 50% of capital cost, subjected to a ceiling of Rs 5 crores
Irrigation systems	Central assistance (subsidy) of upto 50% of the capital costs, subjected to a ceiling of Rs 25 lakhs
Installation of online monitoring systems for flow and pollutant parameters	Central assistance (subsidy) of upto 25% of the capital costs, subjected to a ceiling of Rs 25 lakhs

▪ **Facilitation of development of skilled manpower for operation and management of CETPs**

The CETP operations require trained and qualified manpower with skills to operate and manage the pollution control equipment and have knowledge to manage different types of pollution.

To facilitate development of human capacities catering to CETPs, MoEF should support certified CETP operators and managers. The central assistance from MoEF should include the following:

Training costs of individuals -CETP operators	Central assistance (subsidy) of upto 75% of the training cost, limited to a maximum of Rs 15,000 per participant.
Training costs of individuals -CETP managers	Central assistance (subsidy) of upto 50% of the training cost, limited to a maximum of Rs 15,000 per participant.

One time support to the training institutions	Central assistance (subsidy) of upto 80% of the costs, limited to a maximum of Rs 30 lakhs per institute towards development costs for the training courses, training materials, seeking certification approvals from competent authorities in the government for the training courses etc.
---	---

▪ **Market development for CETPs**

There are enough companies in the market in the country dealing with CETP services. To promote market development, the Central Government should initiate following actions:

- » Empanelment of CETP service providers based on well-defined quality criteria
- » Tax exemptions for a fixed term of say at least 5 years.
- » Bring out Green Procurement Guidelines for CETP services that make qualification criteria, bidding process etc. transparent. Such guidelines will help procure goods, services and construction works for CETPs of good quality with a reduced environmental impact throughout their life cycle when compared to goods, service and works with the same primary function that would otherwise be procured.

▪ **Support for energy efficiency**

The central assistance should include the following:

The biological process consumes high energy followed by wastewater pumping. Around 30% to 40% energy savings could be achieved by promoting energy efficient equipment and energy friendly process.

Energy audits	Central assistance (subsidy) of upto 50% grant for expenditure incurred on audits subject to a maximum of Rs. 1 lakh and subject to improvements/ correctives affected.
Renewable energy	Appropriate incentives under the existing schemes of Government of India and State Governments will be available

▪ **Promotion of Zero Liquid Discharge**

Zero Liquid Discharge (ZLD) is a process that is beneficial to industrial and municipal organizations as well as the environment because it ensures that there is no effluent, or discharge is left over from the wastewater treatment. ZLD systems employ the most advanced wastewater treatment technologies, viz. reverse osmosis, evaporators, crystallisers etc. to purify and recycle virtually all of the wastewater produced.

The central assistance from MoEF should include the following:

Setting up of Zero Liquid Discharge Plant	<p>Central assistance (subsidy) of 50% of the total project cost subject to a ceiling of Rs. 40 crore for projects with provision of ZLD.</p> <p>The State share shall be 25% of the total project cost.</p> <p>The project proponent's contribution shall be 25% out of which at least 15% shall be the contribution of the project proponent and the balance could be raised by the concerned project proponent from loan from Banks/Financial institutions</p>
Exemptions of duties and taxes during setting up of CETP as well as during its operation	<p>Exemption of import duties completely</p> <p>Exemption of income tax and service tax for a period of 5 years</p>

▪ **Promotion of R & D related to CETPs**

To promote R&D to enable indigenous development of innovative and economically viable technologies related to conveyance, treatment, monitoring etc. for CETPs, The central assistance from MoEF should include the following:

Support for carrying our R&D on CETPs	Central assistance (subsidy) of 80% of the total project cost subject to a ceiling of Rs. 50 lakhs per institute.
---------------------------------------	---

^^^



Indo German Environment Partnership Programme
Deutsche Gesellschaft für Internationale Zusammenarbeit (GIZ) GmbH
3rd Floor, B5/2 Safdarjung Enclave
New Delhi 110 029

T +91 11 49495353, Ext: 2358

F +91 11 49495391

E: contact@igep.in

I: www.igep.in; www.giz.de; www.ecoindustrialparks.net
